

OLYMPUS®

CAMERA

INSTRUCTIONS

DIGITAL CAMERA

C-3030ZOOM

PREPARATION

BASIC FUNCTIONS

MOVIE FUNCTIONS

**STORING DATA FOR PRINTING
PICTURES**

USING A PERSONAL COMPUTER

CAMERA SETTINGS

MISCELLANEOUS

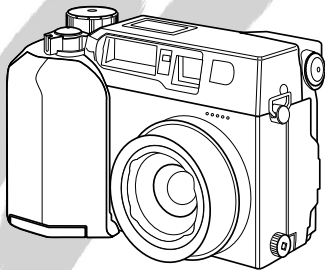

- Before using your camera, read this manual carefully to ensure correct use.
- We recommend that you take test shots to get accustomed to your camera before taking important photographs.

- IBM is a registered trademark of International Business Machines Corporation.
- Microsoft and Windows are registered trademarks of Microsoft Corporation.
- Macintosh is a trademark of Apple Computer Inc.
- All other company and product names are registered trademarks and/or trademarks of their respective owners.

IMPORTANT NOTICE

Disclaimer of Warranty

Olympus makes no representations or warranties, either expressed or implied, by or concerning any content of these written materials or software, and in no event shall be liable for any implied warranty of merchantability or fitness for any particular purpose or for any consequential, incidental or indirect damages (including but not limited to damages for loss of business profits, business interruption and loss of business information) arising from the use or inability to use these written materials or software. Some states do not allow the exclusion or limitation of liability for consequential or incidental damages, so the above limitations may not apply to you.

Copyright Notice

All rights reserved. No part of these written materials or software may be reproduced or used in any form or by any means, electronic or mechanical, including photocopying and recording and the use of any kind of information storage and retrieval system, without prior permission in writing from Olympus. No liability is assumed with respect to the use of the information contained in these written materials or software, or for damages resulting from the use of the information contained in these written materials or of the software. Olympus reserves the right to alter the features and contents of this publication or software without obligation or advance notice.

WARNING:

Unauthorized photographing or use of copyrighted material may violate applicable copyright laws. Olympus assumes no responsibility for unauthorized photographing, use or other acts that infringe upon the rights of copyright owners.

- * If you have any questions about this product, please consult your nearest Olympus dealer in the provided Authorized Distributors List. (Refer to the Technical Hotline Numbers for technical support, and the Authorized Distributors for repair service, etc.)

PRECAUTIONS

This camera is not recommended for commercial use or for use under severe conditions. This camera is a precision instrument. Use caution when handling the unit. Do not apply strong vibration or pressure to the camera or lens, as this may cause damage to the finely tuned internal parts.

GENERAL PRECAUTIONS

In case of problem

- Do not use the camera if it seems not to function correctly. Take the batteries out or disconnect the AC adaptor immediately, and consult your dealer or an Authorized Service Centre.

Do not open or modify

- Do not disassemble the camera, as it may cause damage to the unit. For internal repairs, consult your dealer or an Authorized Service Centre.

Protect from humidity and dust

- Do not store in dusty places, as using the camera afterwards may result in a fire or an electric shock.
- If the unit has been dropped, or if liquid or a foreign object has entered the unit, do not use it, but consult your dealer or an Authorized Service Centre. Do not touch the internal parts. They include high tension circuits that may cause severe electric shock.

Protect from high temperatures

- Do not leave the camera in a closed car, etc. in the sun, as the temperature may rise and cause damage.

Cleaning

- Before servicing or cleaning the unit, be sure to disconnect the AC adaptor.
- The camera can be cleaned by wiping with a soft cloth. To remove stains, wipe with a soft cloth moistened with a mild detergent solution and wrung dry, then wipe with a dry soft cloth.
- Do not use benzene, thinner, or any other chemical product on the camera, as it may have a corrosive effect.

PRECAUTIONS WHEN USING THE CAMERA

Caution concerning the flash

- Be careful when taking pictures at close range.
- Do not take pictures of people's faces (babies in particular) at close range. If the flash goes off too close to someone's eyes it may cause a loss of vision. In particular, when taking pictures of babies, be sure that the distance is at least 1 m.

Be careful when handling the unit

- Do not use in an unstable position. If you lose your balance, you might get hurt.
- Be careful that no foreign substance (dirt, rain, sand) can enter the unit, particularly when the battery cover or lens barrier is open, as it may cause damage.
- To prevent damage, do not drop the camera or subject it to severe shock or vibration.
- This camera is not water-resistant. Do not put it in water, and be careful to protect it from rain, sea water, etc.
- Do not use the camera outside during a storm or when there is lightning.
- When replacing the batteries, make sure the power is OFF. If it is left ON, it may damage the internal circuits.

Storage environment

- To avoid damage or mis-operation of the camera, only store it where the temperature is $-20 \sim 60^{\circ}\text{C}$ and the humidity 10 ~ 90%.
- Do not store in humid places, as condensation may form and cause damage.
- To prevent injuries or accidents, keep the camera out of the reach of children.

Usage environment

- Do not use where there may be a large concentration of flammable or explosive gases, as it may cause a fire or explosion.
- To avoid damage or mis-operation of the camera, use it only if the temperature is $0 \sim 40^{\circ}\text{C}$ and the humidity 30 ~ 90%.
- Do not move the camera suddenly from a hot to cold place, or vice versa. It may cause the formation of condensation inside the unit that may damage it. To prevent the formation of condensation, put the camera in a plastic bag, etc. to protect it and wait until the camera has reached the ambient temperature before taking it out.
- If used in low temperatures, the batteries will have a shorter life span than normal.

Precautions on using accessories

- Be sure to use only the supplied accessories, or accessories recommended by the manufacturer, otherwise fire, electric shock or damage may result. For more information, please consult the dealer where the unit was purchased.
- Do not keep the AC adaptor connected when not using the camera, otherwise fire, electric shock or damage may result.
- To prevent electric shock and damage, do not plug, connect or handle the AC adaptor with wet hands.
- Do not modify, bend forcibly, pull strongly, scratch, etc., or otherwise alter the AC adaptor power cord. Also, do not put heavy objects on the power cord, or place it close to a heat source as it may result in a fire or electric shock.

Points to verify before using the camera

- If taking particularly important pictures or if you have not used the camera for a long period, first confirm that it functions properly, or consult an Authorized Service Centre.
- We decline all responsibility concerning the loss of data, down time, loss of revenue or any other direct or indirect damage or claims caused by this camera.

Important

- "Note" indicates information you should be aware of.
- Actual product may differ slightly from that shown in illustrations.

PRECAUTIONS WHEN HANDLING THE BATTERIES

To prevent leakage, fire, or damage, please read the instructions carefully and observe the following points:

- Do not heat or throw the batteries into a fire.
- Do not disassemble, modify or solder.
- Do not install with inverted polarity (+, -).
- Do not let metal objects touch the contacts. Do not store or carry loosely with necklaces or hairpins.
- Do not use old batteries together with new ones, and do not use different types of batteries at the same time.
- Do not store them in humid places as they may corrode.
- Do not use if something seems to be wrong.
- Do not use if there is leaking, swelling, a rise in temperature, or any other abnormal condition.
- When using them for the first time, if there are signs of corrosion or if they are warm, please take them back to where they were bought.
- NEVER use any batteries whose body is only partially covered, or not covered at all, by an insulating sheet since they may cause leakage, heat or explosion. There are some commercially available batteries whose body is only partially covered, or not covered at all, by an insulating sheet. NEVER use these batteries.

If there is a leak

- If the liquid gets into your eyes, do not rub them. Rinse with clean water, then seek medical attention immediately.
- If the liquid gets in contact with your skin or clothing, rinse with clean water.
- If the liquid has leaked inside the battery compartment, clean it carefully with a wet rag before inserting new batteries.

When the batteries are dead, take them out of the camera

- If old batteries are left inside the camera they may leak. If the camera is going into storage or if you intend not to use the camera for a long period of time, remove the batteries.

Do not use in an airtight device

- If may cause the batteries to leak and/or the camera to be damaged.

Do not recharge alkaline or lithium batteries

- If you try to recharge them, it may cause the batteries to leak and/or the camera to be damaged.

Do not use or store in a hot place (e.g. inside a closed car on a hot and sunny day)

- If may shorten their service life. Store in a dry cool place protected from direct sunlight.

Keep out of the reach of children

- Make sure children do not take the batteries out when using the camera. If a child is going to use the camera, be sure to teach the child proper usage according to this manual.
- When disposing of old batteries, be sure to do so in accordance with all applicable regulations in your area.

CONTENTS

Important notice.....	2
Precautions.....	3
Precautions when handling the batteries.....	6
Main features.....	13

1 PREPARATION15

Checking the contents.....	16
Names of parts.....	18
Attaching the strap.....	21
Loading the batteries.....	22
Using the AC adapter (optional).....	24
Inserting SmartMedia.....	26
Adjusting the date and time.....	28
Learning the basics.....	30
Basic operating procedure.....	30
How to use the Mode dial.....	31
Holding the camera.....	32
Adjusting the diopter.....	33
Proper shutter release.....	33
Checking the card.....	34
Checking the batteries.....	35
Checking the number of storable pictures.....	36
How to use the menu.....	38

2 BASIC FUNCTIONS41

[Record Mode]

Taking pictures.....	42
Taking pictures using the optical viewfinder.....	42
Taking pictures using the LCD monitor.....	44
Quick view.....	46
Focus lock.....	47
Autofocus.....	48
Working range.....	50
AE lock.....	51
Aperture priority mode.....	52

Shutter priority mode	53
Manual mode.....	55
Zoom	56
Exposure compensation	57
Using the flash.....	58
Spot metering mode	62
Macro mode.....	63
Macro + Spot metering mode	64
Manual focus	65
Still picture record menu.....	67
Sequence mode	68
Selftimer/Remote control	70
Auto bracket	74
White balance.....	76
ISO	78
Flash correction	80
Slow shutter synchronization flash mode	82
Extension flash photography	84
Taking photographs using the FL-40 extension flash	84
Taking photographs with the FL-40 extension flash only	86
Taking photographs with another brand of extension flash.....	87
Digital zoom mode.....	90
Picture effects.....	92
Sound record mode	93
Panorama mode	95
Card setup (card format)	97
Selecting the recording mode.....	99
A/S/M mode.....	101
[Display Mode]	
Displaying recorded pictures	102
Index-display mode	104
Close-up display mode (3X inspection)	105
Protection	106
One-frame erase	107
Still picture display menu.....	108

CONTENTS (Cont.)

Slide-show mode	109
Picture information	110
Recording sound	112
Card setup	114
All-frame erase	114
Card format	116
Connecting to a television	118

3 MOVIE FUNCTIONS121

[Record Mode]

Recording movies	122
Recording movies using the LCD monitor	122
Quick view	124
Focus lock	125
Working range	126
Zoom	127
Exposure compensation	128
Manual focus	129
Movie picture record menu	131
Selftimer/Remote control	132
White balance	136
ISO	138
Picture effects	140
Card setup (card format)	141
Selecting the recording mode	143

[Display Mode]

Movie picture display menu	145
Playing movies	146
Picture information	148
Functions	150
Creating an index	150
Editing a movie	152
Card setup	154
All-frame erase	154
Card format	156



4 STORING DATA FOR PRINTING PICTURES159

About print settings.....	160
Print-reserve	162
All-frame print reserve	162
Single-frame print reserve	164
Trimming print reserve	168
Resetting print reserve.....	171

5 USING A PERSONAL COMPUTER173

Computer system requirements	174
Installing provided software	175
Connecting to a personal computer.....	176
Using a personal computer.....	177
Transferring data from SmartMedia.....	178
PC card adapter	178
FlashPath floppydisk adapter	178
SmartMedia READER/WRITER	178
Using CAMEDIA Master	179
Processing images using CAMEDIA Master	181

CONTENTS (Cont.)

6	CAMERA SETTINGS	187
	All reset.....	188
	Custom settings.....	190
	Sharpness	193
	TIFF settings.....	194
	SQ1, SQ2 settings.....	196
	Beep sound	198
	Full-time AF	199
	Rec view	201
	File number.....	206
	LCD brightness.....	209
	Meters/Feet selection	211
	Index-display adjustment.....	212
7	MISCELLANEOUS	213
	Questions and answers	214
	Troubleshooting.....	216
	System chart.....	220
	Error codes	221
	Optional items.....	223
	Notes on display and backlight.....	223
	Compatibility of the picture data	224
	Specifications	226

MAIN FEATURES

- This camera's 3,340,000-pixel CCD and Olympus high-resolution optical lens deliver the highest picture quality in its class.
- Various exposure modes make advanced shooting possible.
- Sequential shooting at high shutter speeds (max. 3.1 frames/second) is possible in all modes except TIFF.
- The Olympus high-resolution 3X optical zoom lens plus the Digital Zoom make possible photographs equivalent to 7.5X zoom.
- Movie function incorporated that lets you record up to approx. 218 seconds in the SQ mode and approx. 55 seconds in the HQ mode when a 16MB card is used.
- Sound can be simultaneously recorded with a movie. Sound can also be recorded with a picture, either when it is shot or afterward.*
- In addition to an optical viewfinder, a 1.8" (4.5 cm) wide-angle TFT LCD monitor is provided for more flexibility when composing shots and viewing images (view can be enlarged 3 times).
- Easy operation with Mode dial and Menu screen.
- A removable SmartMedia (SSFDC) memory card (with Panorama function) is provided.
- With the provided Video output connector, pictures can be viewed on a TV.
- Pictures can be reserved in SmartMedia cards to be printed on printers or at photo labs that support the DPOF system.

MAIN FEATURES (Cont.)

- **USB-compatible.** Either a serial or USB interface can be used to connect to a personal computer.
- **Write times are shorter,** enabling the camera to be ready for the next shot quicker.
- **When the FL-40 extension flash (optional) is used,** sophisticated flash photographs can be taken.

* Sound cannot be played back by this camera. Connect it to a TV or personal computer for sound playback.

CAMERA

1

PREPARATION

OLYMPUS DIGITAL CAMERA

CHECKING THE CONTENTS

Camera

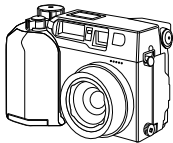

Strap

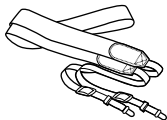

Remote control



A/V cable

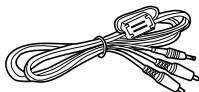

Lens cap



Warranty card



CR-V3 lithium battery pack
(2 packs)

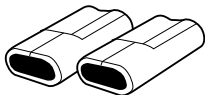

Instructions (concise
version) /Remote control
instructions

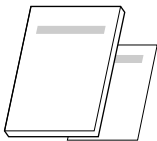

RS-232C PC serial cable

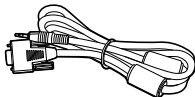

Software CD's (including
instructions on CD-ROM)



USB cable



SmartMedia
(SSFDC-16MB)



Static-free case



Index labels (2 pieces)



Write-protect adhesive
seals (4 pieces)



Instructions



NAMES OF PARTS

CAMERA

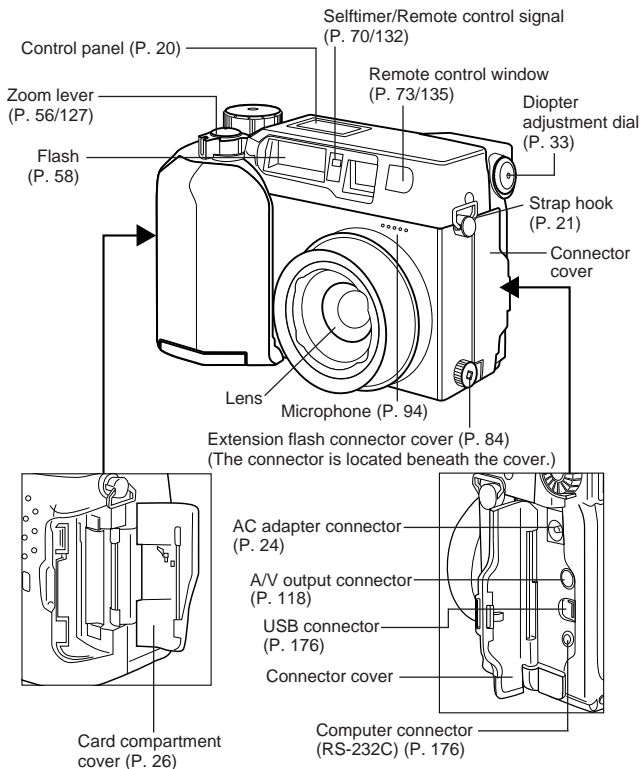

Flash button (P. 58)/Erase button
(P. 107)

Spot/Macro button
(P. 62) /
Print button (P. 162)

Viewfinder
(P. 19)

LCD monitor
(P. 20)

Battery compartment
cover (P. 22)

Battery compartment open/close
switch (bottom) (P. 22)

Mode dial (P. 31)

Jog dial (P. 38)

Shutter release button
(P. 33)

Zoom lever
(P. 56/127)

OK button (P. 39)
MF button (P. 66/
130)

Protect button
(P. 106)

LCD monitor
ON/OFF button
(P. 44/122)

Card access
lamp (P. 30/33)

Menu button
(P. 38)

Threaded mount (bottom)

VIEWFINDER DISPLAY

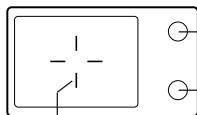

Orange lamp
(flash) (p. 58)

Green lamp
(p. 42/51)

Autofocus mark (p. 42/47/125)/
Backlighting correction mark (p. 59)

NAMES OF PARTS (Cont.)

CONTROL PANEL

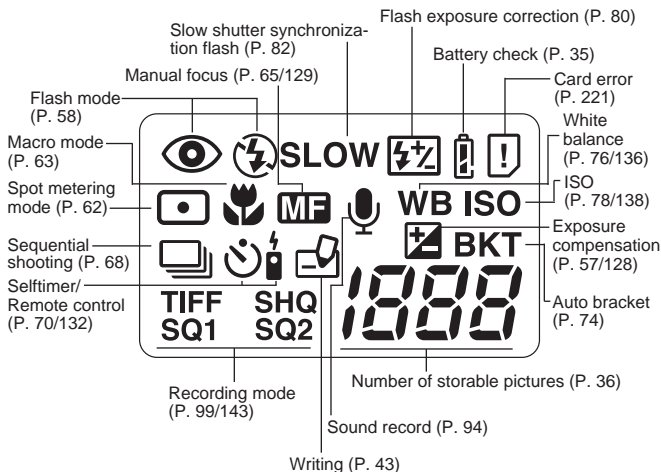

LCD MONITOR

(Display mode)

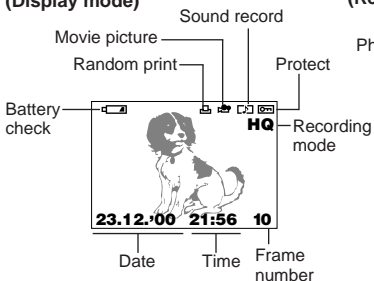

(Record mode)

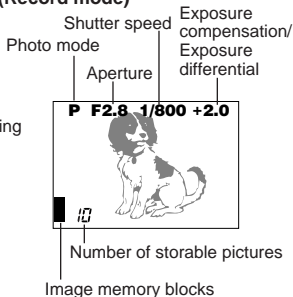

ATTACHING THE STRAP

Attach the strap to the strap hook on the camera.

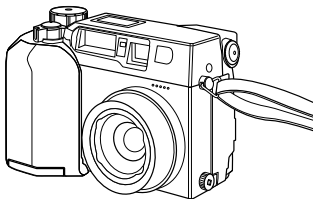

-
- 1** Thread the strap through the strap hook as shown in the illustration, then pull on it to make sure it is attached securely.

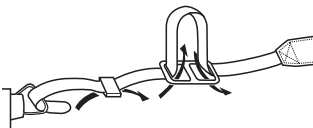
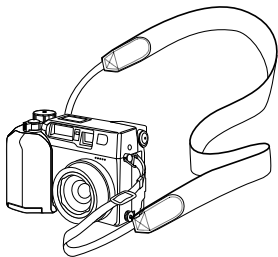

Caution: _____

- Attach the strap correctly as shown so that the camera does not fall off. If the strap is attached incorrectly and the camera comes loose and falls off, Olympus is not responsible for any damage.

LOADING THE BATTERIES

This camera uses 2 CR-V3 lithium battery packs or 4 AA (R6) NiMH batteries, NiCd batteries, alkaline batteries or lithium batteries.

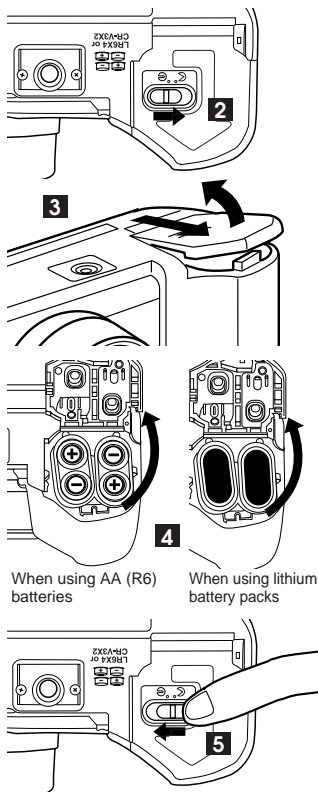

- 1** Make sure that the camera power is off.
- 2** Slide the opening and closing switch on the battery cover in the direction of ➤.
- 3** Slide the battery cover in the direction of the arrow printed on it with your fingertip to open it.
 - If you attempt to open it using a fingernail, it could result in injury.
- 4** Insert the batteries with their poles oriented in the right direction.
 - Insert the battery packs with the CAMELIA labels facing outward and the concave terminals facing each other.
- 5** Close the battery cover, then press it down and slide it in the opposite direction of the arrow printed on it. Slide the opening and closing switch on the battery cover in the direction of ⊖. The switch will not lock unless the cover is completely closed.
 - When pressing the battery cover shut, be sure to press the center of the cover since it may be difficult to close properly by pressing the edge.

Note:

- CR-V3 lithium battery packs cannot be charged.
- Alkaline batteries have a lot of variation in their performance and deteriorate particularly at low temperatures. It is recommended that lithium battery packs or NiMH batteries be used.
- Zinc-carbon batteries cannot be used. Please read the cautions concerning batteries. (See page 6.)
- Do not touch the inside of the battery compartment.
- If the terminals inside the battery compartment are dirty, it will markedly shorten the life of the batteries.
- If the camera is left for 1 hour with the batteries removed, all the internal settings will revert to the default settings.



These batteries cannot be used.

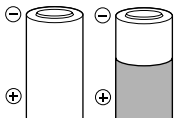

Batteries whose body is only partially covered, or not covered at all, by the insulating sheet.

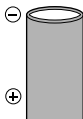

Batteries whose \ominus terminal is flat and a part of the terminal is covered by the insulating sheet.

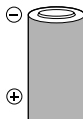

Batteries whose \ominus terminal is raised but not covered by the insulating sheet.

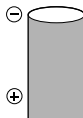

Batteries whose \ominus terminal is flat and not covered by the insulating sheet.

USING THE AC ADAPTER (Optional)

An optional Olympus AC adapter allows you to power your digital camera from a common AC wall outlet.

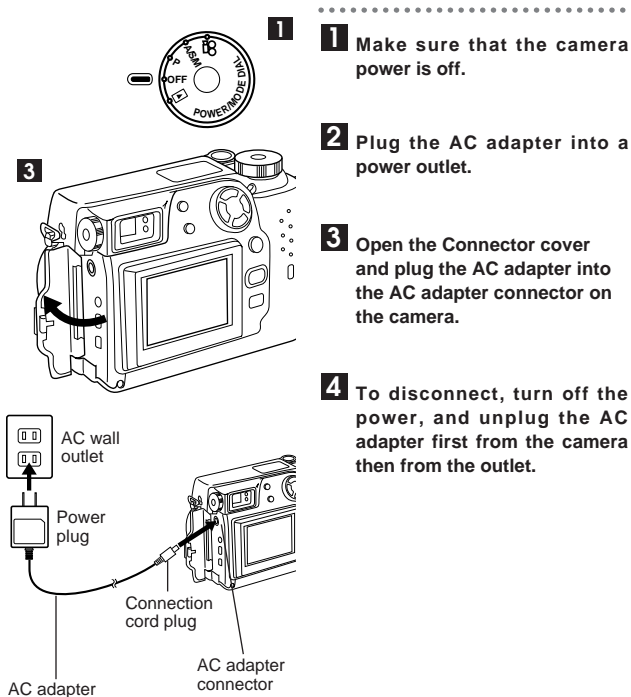

Note:

- When in use for long periods, the AC adapter may get warm. This is normal.



Warning:

Incorrect use may cause a fire or electric shock.

- Be sure to use an Olympus AC adapter. Olympus is not responsible for any damage caused by the use of other kinds of AC adapters.
- Use an AC220V power source.
- NEVER connect or disconnect the AC adapter with wet hands.
- If the cord of the AC adapter is hot, smells like smoke or is emitting smoke, unplug it immediately and contact your nearest authorized Olympus service center.
- Make sure that the camera power is off before connecting or disconnecting the AC adapter.
- Make sure the AC adapter is properly plugged into the outlet.
- When disconnecting, hold the body, not the cord, of the AC adapter. Never pull, bend, twist or modify the cord.
- If there is any damage on the cord or if there is a contact failure, stop using it and contact your nearest authorized Olympus service center.
- Keep the AC adapter disconnected when the camera is not in use.

INSERTING SmartMedia

Insert the SmartMedia card in the direction shown.

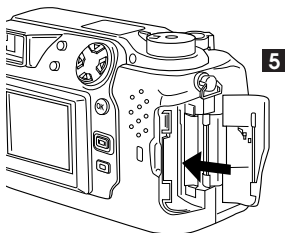
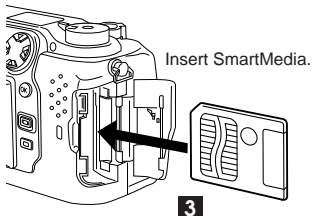
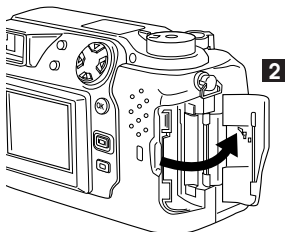
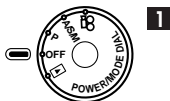

Push the card to eject it.

.....
1 Make sure that the camera power is off.

2 Open the Card compartment cover.

3 Insert the SmartMedia card in the direction shown in the illustration.

- Note the orientation of the card. If it is inserted incorrectly, it may become jammed.
- When using a special function SmartMedia card (optional), insert it in the same way.

4 Close the cover tightly.

5 To eject the card, turn off the power, open the Card compartment cover and push the card.

Note:

- **Use 3V (3.3V) cards only.** 5V cards cannot be used.
- Olympus brand cards are recommended (already formatted). Non-Olympus brand cards must be formatted by the camera.
- When using a special function SmartMedia card (optional), insert it in the same way.



Caution:

- **NEVER** open the card cover, eject the card, remove the batteries, or pull the plug while the camera is in operation. It may destroy the data in the card.
- The card is a precision instrument. Handle it carefully and do not subject it to physical shocks.
- Do not touch the contact area of the card.

ADJUSTING THE DATE AND TIME



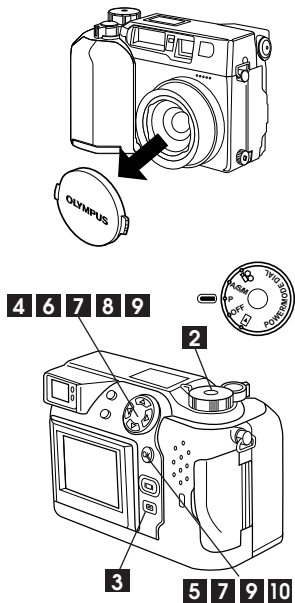

You can adjust the date and time.

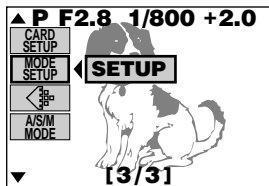

LCD monitor



(Still picture record menu)

- 1** Remove the lens cap.
- 2** Set the Mode dial to P, A/S/M,  or  .
 - When no images are recorded in a card, set it to a mode other than  .
- 3** Press the Menu button to display the Menu.
 - See page 44 for how to use the Menu.
- 4** Press the top/bottom arrows on the Jog dial to select MODE SETUP, then press the right arrow.
- 5** Select SETUP, then press the OK button to display the Mode setting screen.
- 6** Press the top/bottom arrows on the Jog dial to select  .
- 7** Press the right arrow on the Jog dial to select SETUP, then press the OK button.

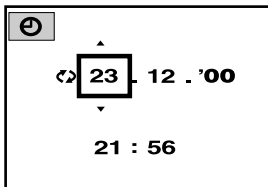
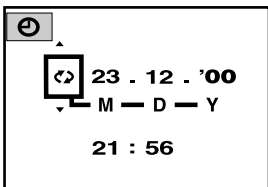
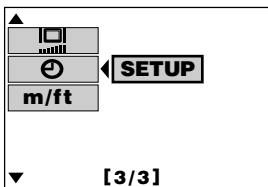

8 Select the date order using the top/bottom arrows on the Jog dial. Press the right arrow on the Jog dial to adjust the first setting (day/month/year).

9 Press the top/bottom arrows on the Jog dial to adjust the first setting, then press the right arrow on the Jog dial to adjust the second setting. Repeat until the minute is adjusted. Press the OK button.

- For accurate setting, press the OK button when the clock hits 00 seconds.
- '00 will appear for the year 2000.

10 Press the OK button to save the setting. Press again to cancel the Menu.



Caution:

- The adjusted date will be canceled when the camera is left without batteries for approx. one hour (based on our tests). In such a case, adjust the date again.

Note:

- We recommend that you check the date and time before taking important pictures.
- The setting will remain until it is readjusted.
- When the Mode dial is set to , the card must contain images in order to display the Menu.

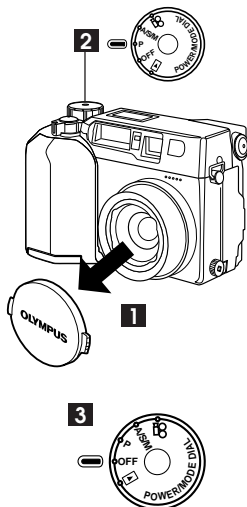

LEARNING THE BASICS

BASIC OPERATING PROCEDURE



1 Remove the lens cap.

2 Set the Mode dial to P, A/S/M,  or  to turn on the power.

- A/S/M, P and  set the camera to the Record Mode. The lens will come out and the remaining battery power as well as the number of storable pictures will be displayed on the control panel.
-  sets the camera to the Display mode. The LCD monitor will be turned on.

3 After use, set the Mode dial to OFF to turn off the power.

- The lens will retract and the LCD monitor and control panel will turn off.
- Be sure to replace the lens cap on the camera when it is not in use.

Note:

- Do not turn on the power without removing the lens cap first.
- NEVER open the card cover, eject the card, remove the batteries, or pull the plug while the camera is in operation (while the Card access lamp is blinking). It may destroy the data in the card.
- If you do not operate the camera for three minutes, the camera will be set to the stand-by mode. After four hours in the stand-by mode, the power turns off automatically. (Time varies depending on the type of batteries used.)
- The recorded images will remain in the card even after the power is turned off or the batteries are replaced.

HOW TO USE THE MODE DIAL

You can easily turn the camera on or off or change the mode using the Mode dial.

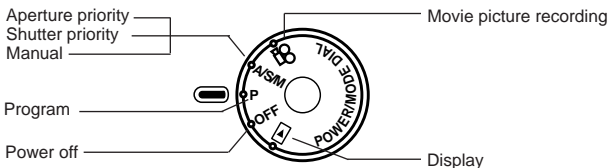

P or A/S/M (Still picture recording) (p. 42 ~ 101)

With P, the camera selects the optimal aperture and the shutter speed automatically.

With A/S/M, you can set the aperture or the shutter speed or both for yourself. (p. 52 ~ 55)

📹 (Movie picture recording)

You can shoot movies of up to approx. 218 seconds in length in the SQ mode and 55 seconds in the HQ mode (when a 16MB card is used). (p. 122 ~ 143)

OFF (Power off)

▶ (Display)

You can observe the pictures you have taken.

LEARNING THE BASICS (Cont.)

HOLDING THE CAMERA

Hold the camera firmly with both hands while keeping your elbows at your sides to prevent the camera from moving.

Proper



Proper

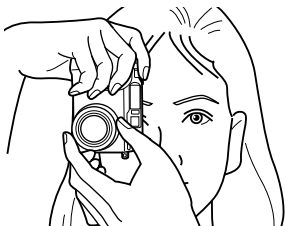

Improper

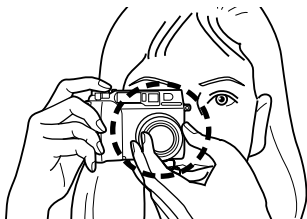

Note:

- Do not subject the lens to physical shocks.
- Keep your fingers and the strap away from the lens and flash.
- When shooting vertically-oriented pictures, hold the camera so that the flash is at the top.

ADJUSTING THE DIOPTER

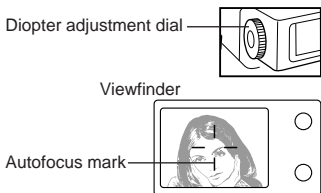

- Turn the Diopter adjustment dial to see the Autofocus mark clearly.

PROPER SHUTTER RELEASE

Press the Shutter release button halfway to lock the focus and exposure.

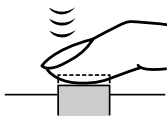

- The Green lamp next to the viewfinder lights.
- If the Green lamp blinks, the focus or exposure is not locked.
- To focus the camera when the subject of the picture is outside the auto focus mark, use focus lock. (p. 47/125)

Press the Shutter release button fully to release the shutter and take the picture.

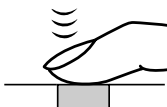

- The camera emits a beep sound when the shutter is released.
- The Card access lamp blinks while the picture is being recorded.

Note:

- Press the Shutter release button gently using the ball of your finger.
- Avoid moving the camera when pressing the Shutter release button to prevent blurry pictures.

LEARNING THE BASICS (Cont.)

CHECKING THE CARD

When the power is turned on in the Record Mode, the camera checks the SmartMedia card.

Control panel

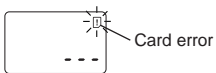

Viewfinder

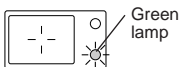

When there is no SmartMedia card in the camera / the card is protected:

The Card error indicator on the control panel and the Green lamp blink.

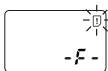

LCD monitor

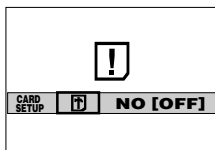

When the card needs to be formatted:

The Card error indicator on the control panel lights, and the Card format confirmation screen appears. Select **F** to enter the Card format mode. (p. 97)

CHECKING THE BATTERIES

When the power is turned on in the Record Mode, the remaining battery power will be displayed on the control panel.



lights and turns off automatically.

Batteries are OK. You can shoot.



blinks and other indicators on the control panel are displayed normally.

Battery power is low and batteries should be replaced.



blinks and other indicators on the control panel go out.

Batteries are dead and should be replaced immediately.

- The timing of each battery level indicator varies depending on the type of batteries used.
- If NiMH batteries are used, the battery low warning will blink faster than when lithium battery packs are used.

Note:

- When taking pictures on a special occasion, on a trip, or in cold temperatures, keep spare batteries handy. (p. 6)
- When the camera is being operated on batteries that are running low, the camera may emit several short beeps and blink the number of storable pictures on the control panel after you take a shot or when you turn on the power. If this happens, the picture you have just taken will not turn out properly. Replace the batteries and take the picture again.

LEARNING THE BASICS (Cont.)

CHECKING THE NUMBER OF STORABLE PICTURES

When the power is turned on in the Still Picture Record Mode, the number of storable pictures will appear on the control panel. (For movie pictures, the seconds remaining will appear.)

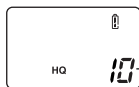

Number or storable pictures

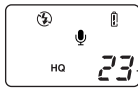

Seconds remaining

- The Green lamp blinks and CARD FULL appears on the LCD monitor when the number reaches 0. (p. 221)
- The number of storable pictures varies depending on the selected recording mode. See page 99 for selecting the recording mode.

Number of Still Pictures that can be Taken (without sound)

Recording mode		Number of pixels	File	Memory capacity					
				2MB	4MB	8MB	16MB	32MB	64MB
TIFF		2048 x 1536	TIFF	0	0	0	1	3	6
		1600 x 1200		0	0	1	2	5	11
		1280 x 960		0	1	2	4	8	17
		1024 x 768		0	1	3	6	13	27
		640 x 480		2	4	8	17	34	68
SHQ		2048 x 1536	JPEG	0	1	3	6	13	27
HQ		2048 x 1536		2	4	10	20	40	81
SQ1	HIGH (High quality)	1600 x 1200		1	2	5	11	22	45
	NORMAL			3	7	16	31	64	128
	HIGH (High quality)	1280 x 960		2	4	8	17	34	70
	NORMAL			5	12	24	49	99	199
SQ2	HIGH (High quality)	1024 x 768		3	6	13	26	53	107
	NORMAL			9	18	37	76	153	306
	HIGH (High quality)	640 x 480		7	16	32	66	132	266
	NORMAL			20	40	82	165	331	665

Number of Still Pictures that can be Taken (with sound)

Recording mode		Number of pixels	File	Memory capacity					
				2MB	4MB	8MB	16MB	32MB	64MB
TIFF		2048 x 1536	TIFF	0	0	0	1	3	6
		1600 x 1200		0	0	1	2	5	11
		1280 x 960		0	1	2	4	8	17
		1024 x 768		0	1	3	6	13	27
		640 x 480		1	4	8	16	33	66
SHQ		2048 x 1536	JPEG	0	1	3	6	13	27
HQ		2048 x 1536		2	4	9	19	39	78
SQ1	HIGH (High quality)	1600 x 1200		1	2	5	11	22	44
	NORMAL			3	7	15	30	60	120
	HIGH (High quality)	1280 x 960		2	4	8	16	33	67
	NORMAL			5	11	22	45	90	181
SQ2	HIGH (High quality)	1024 x 768		3	6	12	25	51	102
	NORMAL			7	16	32	66	132	266
	HIGH (High quality)	640 x 480		6	14	28	58	117	234
	NORMAL			15	30	61	123	248	498

- Sound cannot be recorded with a picture in the TIFF mode, but it can be added later in the  mode. (p. 112)

Seconds that Movies can be Photographed

Recording mode	Number of pixels	Memory capacity				
		2MB	4MB	8MB	16MB	Over 32MB
HQ	320 x 240	6	13	27	55	75
SQ	160 x 120	25	53	108	218	300

Note:

- Because the amount of data used varies depending on the subject, more/fewer pictures than the number shown may be photographed.
- The number of storable pictures may not be reduced every time a picture is taken, or increased when a picture is erased.
- Numerical values are approximate.

LEARNING THE BASICS (Cont.)

HOW TO USE THE MENU

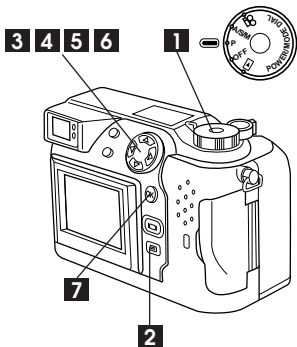

.....
1 Set the Mode dial.

2 Press the Menu button to display the Menu.

3 Press the top/bottom arrows on the Jog dial to select the item to adjust.

4 Press the right arrow on the Jog dial to display further selections.

To move the cursor vertically.

Jog dial

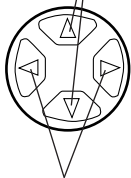

To move the cursor horizontally.

5 Press the top/bottom arrows to adjust the item.

6 When finished, press the left arrow on the Jog dial to confirm the adjustment.

7 Press the OK button to save the adjustment and cancel the Menu.

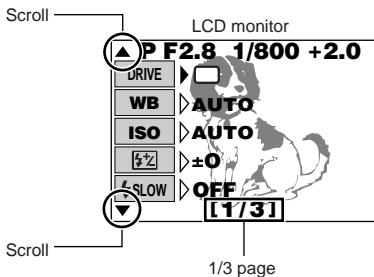

Note:

- When the Mode dial is set to , the card must contain images in order to display the Menu.
- In the Record Mode, you can take pictures without pressing the OK button. The adjustment will be valid until the Menu is canceled.
- Press the Menu button without pressing the OK button to cancel the adjustment and the Menu.
- Unless OFF is selected in All Reset, some adjustments will be canceled and reset to the default when the power is turned off. (p. 188)



2

BASIC FUNCTIONS

TAKING PICTURES

TAKING PICTURES USING THE OPTICAL VIEWFINDER

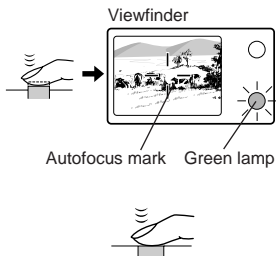
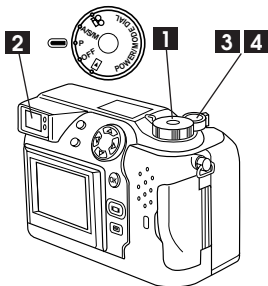

.....

1 Set the Mode dial to P or A/S/M.

2 Compose the picture by placing the subject within the autofocus marks in the viewfinder or using focus lock. (p. 47)

- Turn the Diopter adjustment dial to see the Autofocus mark clearly. (p. 33)

3 Press the Shutter release button halfway to lock the focus and exposure.

- The Green lamp next to the viewfinder lights.
- If the Green lamp blinks, the focus or exposure is not locked. Check the working distance. (p. 50)

4 Press the Shutter release button fully to take the picture.



5 When the Green lamp stops blinking (after about 0.5 ~ 43 seconds), the camera is ready to take the next picture.

- The Shutter will not release while the Green lamp is blinking.



Caution:

- **NEVER** open the card cover, eject the card, remove the batteries, or pull the plug while the Card access lamp is blinking.

Note:

- When the Orange lamp next to the viewfinder blinks, the flash is being charged. (p. 58)
- Printed images will be slightly larger compared with what you see in the viewfinder or on the LCD monitor.

TAKING PICTURES (Cont.)

TAKING PICTURES USING THE LCD MONITOR

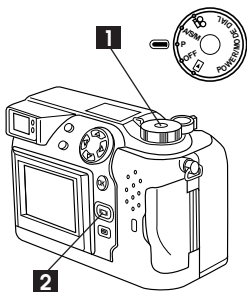

LCD monitor



Number of storable pictures

Image memory blocks

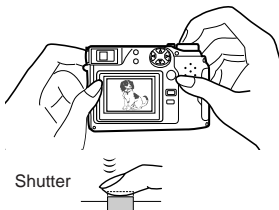

.....

1 Set the Mode dial to P or A/S/M.

2 With P, press the LCD monitor ON/OFF button to turn on the LCD monitor.

- With A/S/M, the LCD monitor will turn on automatically.

3 Compose the picture using the LCD monitor.

4 Take the picture in the same way as you would when using the optical viewfinder. (p. 42)

- The lower image memory block will light and the camera will start storing the image in the card.
- Unless the card is full, the next picture can be taken even while the image is being stored, until all of the blocks light.
- When more than two images are recorded, the center block will light.
- When the buffer memory is full, the upper block will light and no other operation can be performed until the upper block goes off.
- When FULL-TIME AF is activated, pictures displayed on the LCD monitor are always in focus.

LCD monitor



5 When the recorded image is no longer displayed, the camera is ready to take the next picture.

- The recorded image will not be displayed if the Rec view is off. (p. 201)
- If CHECK is selected in REC VIEW in MODE SETUP, you can select whether to save the photographed image or erase it. (p. 202)

Note:

- Do not push the LCD monitor forcibly.
- Pictures that appear on the LCD monitor are for composition purposes only.
- It is recommended to use the optical viewfinder for less camera movement and battery consumption.
- It will take longer to record when the LCD monitor is used.
- When the subject is viewed diagonally in the camera, the edges may appear zigzagged on the LCD monitor. This is not a malfunction; it will be less noticeable in Display mode.
- A strip of light may appear on the top/bottom of the LCD monitor, but this is not a malfunction.
- When a picture is taken in a lighted area, such as in sunlight, vertical lines may appear on the LCD monitor. This is not a malfunction.
- Printed images will be slightly larger compared with what you see in the viewfinder or on the LCD monitor.

TAKING PICTURES (Cont.)

QUICK VIEW

You can immediately shift from the Record Mode to the Display mode, and check the picture you have just taken.

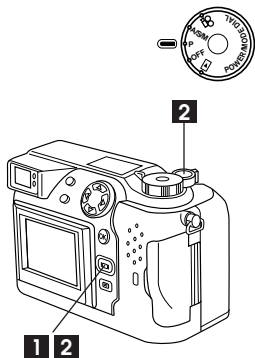

- 1** When the Mode dial is set to P or A/S/M, quickly press the LCD monitor ON/OFF button twice.

- The LCD monitor will display the last picture taken.

- 2** To return to the Record Mode, press the LCD monitor ON/OFF button or the Shutter release button.

FOCUS LOCK

If your main subject is not within the autofocus marks, follow the procedure below to obtain focus. This is called focus lock.

Viewfinder



Autofocus mark



-
- 1** Position your subject within the autofocus marks, and press the Shutter release button halfway.

- The Green lamp next to the viewfinder lights.

- 2** Recompose the picture while keeping the Shutter release button pressed halfway.

- 3** Press the Shutter release button fully to take the picture.

Note:

- If the Green lamp blinks, the focus or exposure is not locked. Check the working distance. (p. 50)

AUTOFOCUS

There are certain conditions where the autofocus may not work properly even when the Green lamp lights when the Shutter release button is pressed halfway. When this happens, try the procedure below or use Manual focus. (p. 65)

① Subjects with low contrast

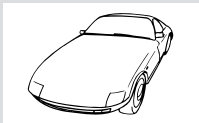

Lock the focus on an object that is at the same distance from the camera as the subject, then aim at the subject to take the picture. (p. 47)

② Subjects with no vertical lines

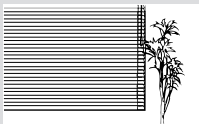

Lock the focus on the subject by holding the camera vertically, then change it to the horizontal position to take the picture. (p. 47)

3 Subjects in excessively bright light



Lock the focus on an object that is at the same distance from the camera as the subject, then aim at the subject to take the picture. (p. 47)

4 Subjects at different distances

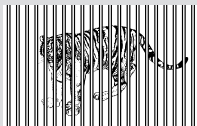

Lock the focus on an object that is at the same distance from the camera as the subject, then aim at the subject to take the picture. (p. 47)

5 Fast-moving subjects at close distances

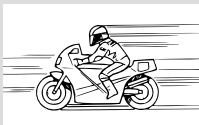

Lock the focus on an object that is at the same distance from the camera as the subject, then aim at the subject to take the picture. (p. 47)

WORKING RANGE

The viewfinder's picture frame shows the area that can be shot for subjects at ∞ . However, the picture area will move lower in the viewfinder as you get closer to the subject, especially with Telephoto shooting.

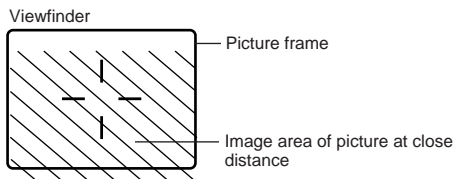

Take pictures at a distance between 0.2 m ~ ∞ .

- Subjects closer than 0.2 m may turn out to be out of focus and incorrectly exposed.
- Using the LCD monitor as a viewfinder makes it easy to take close-up pictures.
- Power consumption increases when the LCD monitor is used.

Working range

Macro mode (p. 63)	0.2 m ~ 0.8 m
Standard mode	0.8 m ~ ∞

AE LOCK

You can take a picture of a subject with a different exposure than that set with focus lock.

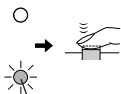
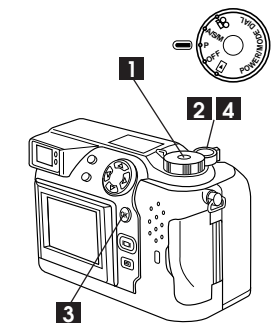

1 Set the Mode dial to P or A/S/M.

2 Position your subject within the autofocus mark, and press the Shutter release button halfway.

3 While keeping the Shutter release button pressed halfway, recompose the picture and press the OK button.

- The exposure is metered and stored in memory.
- If the OK button is pressed again, the new exposure is stored in memory.

4 Press the Shutter release button fully.

- When the Shutter release button is released, the focus lock in step 2 and the exposure stored in memory will both be canceled.

Note:

- If the Shutter release button is released after being pressed halfway, the exposure setting will be canceled even if it was stored in memory.
- If the distance to the subject changes after focus lock is set, the resulting picture will be out of focus.

APERTURE PRIORITY MODE

You can set the aperture manually for the Aperture priority mode. It is especially useful for taking portrait pictures with blurred backgrounds.

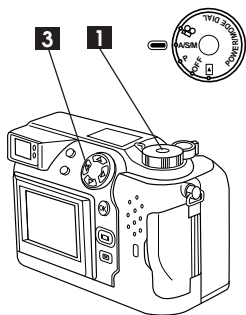

- 1** Set the Mode dial to A/S/M.
 - The LCD monitor turns on automatically, and the aperture setting will be displayed.

- 2** Select the Aperture priority mode from the Menu. (p. 101)

- 3** Press the top/bottom arrows on the Jog dial to select the aperture.
 - ▲ : Increases the value.
 - ▼ : Decreases the value.

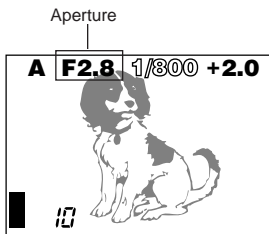

Note:

- When the flash is set to fire automatically, the shutter speed will not go below 1/30 second.
- When the right exposure cannot be attained, the aperture display will blink and ▲ (overexposure) or ▼ (underexposure) will appear on the LCD monitor.
- Aperture setting is valid only when the Aperture priority mode is selected.
- Unless OFF is selected in All Reset, the setting will be canceled when the power is turned off. (p. 188)

SHUTTER PRIORITY MODE

You can set the shutter speed manually for the Shutter priority mode. Set it to a fast speed to capture a moving object. Set it to a slow speed to express motion.

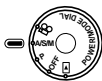
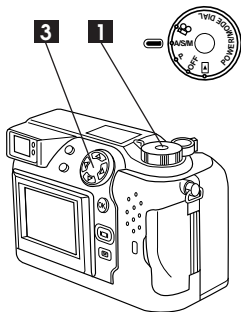

.....

1 Set the Mode dial to A/S/M.

- The LCD monitor turns on automatically, and the shutter speed setting will be displayed.

2 Select the Shutter priority mode from the Menu. (p. 101)

3 Press the top/bottom arrows on the Jog dial to select the shutter speed.

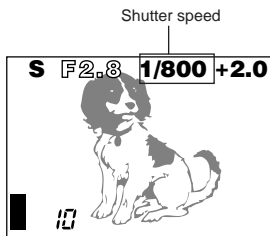

SHUTTER PRIORITY MODE (Cont.)

When the Mode dial is set to A/S/M, ISO is set to 100 automatically. The ISO setting can be selected from 100, 200 or 400. (P. 78)

Changing the ISO setting does not affect the shutter speed setting.

Available shutter speed settings: 1 to 1/800 second.

Note:

- When the right exposure cannot be attained, the shutter speed display will blink and ▲ (overexposure) or ▼ (underexposure) will appear on the LCD monitor.
- Shutter speed setting is valid only when the Shutter priority mode is selected.
- Unless OFF is selected in All Reset, the setting will be canceled when the power is turned off. (p. 188)

MANUAL MODE

You can set the aperture and shutter speed manually in the Manual mode. It is especially useful for taking portrait pictures with blurred backgrounds or expressing motion.

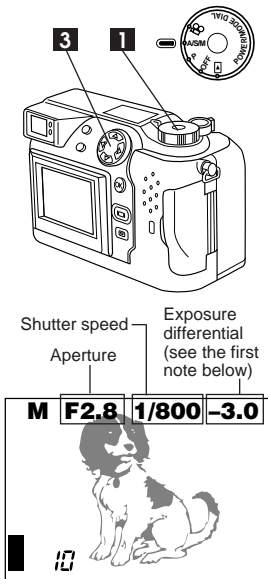

.....

1 Set the Mode dial to A/S/M.

- The LCD monitor turns on automatically, and the aperture and shutter speed settings are displayed.

2 Select the Manual mode from the Menu. (p. 101)

3 Press the right/left arrows on the Jog dial to select the aperture. Press the top/bottom arrows to select the shutter speed.

- The shutter speed can be selected from 16 to 1/800 seconds.

Note:

- The differential (ranging from -3.0 to $+3.0$) between the exposure determined by the currently selected aperture and shutter speed compared to the exposure level considered optimal by the camera appears in the upper right-hand corner of the LCD monitor.
- If the exposure compensation value is lower than -3.0 or higher than $+3.0$, the indication will turn red.
- Manual settings are valid only when the Manual mode is selected.
- Unless OFF is selected in All Reset, the setting will be canceled when the power is turned off. (p. 188)

ZOOM

You can select Telephoto or Wide-angle with the 3X zoom lever.

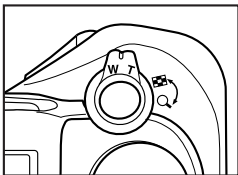

Press the lever forward T for Telephoto shooting.

Press the lever forward W for wide-angle shooting.



Note:

- When used with the Digital zoom mode, you can take an approx. 7.5X zoom photograph. (p. 90)
- Unless OFF is selected in All Reset, the setting will be canceled when the power is turned off. (p. 188)

EXPOSURE COMPENSATION

In addition to automatic exposure, you can also adjust it manually by ± 2 (approx. $1/3$ steps). Adjust $+$ to increase the exposure, and $-$ to decrease the exposure. Confirm the settings by turning on the LCD monitor.

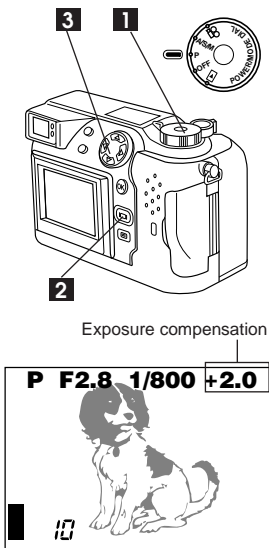

1 Set the Mode dial to P or A/S/M.

- For A/S/M, the Shutter priority mode or Aperture priority mode must be selected. (p. 101)

2 When P is selected, press the LCD monitor ON/OFF button to turn on the LCD monitor.

- With A/S/M, the LCD monitor will turn on automatically.
- The exposure setting will be displayed.

3 Press the right arrow on the Jog dial for $+$ adjustment and the left arrow for $-$ adjustment.

- When set to a value other than 0,  is displayed on the control panel.

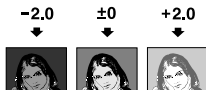

Note:

- Not available in the Manual mode.
- Unless OFF is selected in All Reset, the setting will be canceled when the power is turned off. (p. 188)
- Although the brightness of the LCD monitor can be changed with the exposure compensation, it may not appear to change when the subject is mostly dark. In such a case, display the recorded picture on the LCD monitor to check its brightness.
- The exposure compensation may not work properly when shooting with the flash.

USING THE FLASH

When the shutter button is pressed halfway, the orange lamp next to the finder lights up when use of the flash is necessary. Select a flash mode to match the photographic conditions and purpose.

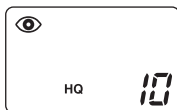

If a setting other than Auto-Flash is selected, the flash mode is displayed on the control panel.

You can select the following flash modes with each press of the Flash mode button.

Flash mode	Use
Auto-Flash (p. 65) ↓	Automatically fires in low-light and backlight conditions.
Red-Eye Reducing Flash (p. 59) ↓	Significantly reduces the phenomenon of "red-eye" (subject's eyes appearing red).
Fill-In Flash (p. 60) ↓	Fires regardless of available light.
Flash Off (p. 60) ↓	Never fires.

Flash working range:

Wide-angle : Approx. 0.8 m ~ 3.8 m

Telephoto : Approx. 0.2 m ~ 3.8 m

Note:

- The amount of flash light can be compensated for to match the picture subject. (p. 80)
- The flash is being charged while the Orange lamp is blinking. Wait until the Orange lamp goes off to take the picture.
- When using the flash in the Macro mode, especially with Wide-angle shooting, the flash may not have the proper effect. Confirm the result using the LCD monitor.
- See page 84 for using an extension flash.
- The main flash cannot be used in the Sequence mode. (p. 68)

AUTO-FLASH

The flash will fire automatically in low-light and backlight conditions.

Viewfinder



Backlighting correction mark

When you take a picture that is backlit, position the subject within the backlighting correction marks to fire the flash.

RED-EYE REDUCING FLASH



This mode significantly reduces the phenomenon of "red-eye".



Control panel

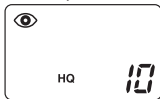

Note:

- The camera emits pre-flashes before the regular flash.
- It takes about a second before the Shutter is released.
- Performance may be limited when the subject is not looking at the pre-flashes from right in front of the camera, or due to medication/alcohol intake or individual characteristics.

USING THE FLASH (Cont.)

FILL-IN FLASH (FORCED ACTIVATION) ⚡

The flash fires regardless of available light. For example, this mode can be used to brighten up the subject's shaded face. Another use of this mode is to correct the color shift produced by artificial lights (eg. fluorescent light).



Control panel

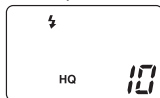

Note:

- Use this mode within the flash working range. (p. 58)
- It may not have the desired effect under excessively bright light.

OFF (FLASH OVERRIDE) ⓧ

The flash does not fire even in low-light conditions. Use this mode in situations where flash photography is not desired or is prohibited, or in twilight/night scenes.



Control panel

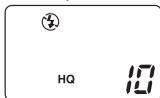



Note:

- Since a slow shutter speed is automatically selected in low-light situations when in the Off mode, the use of a tripod is recommended to prevent blurred pictures caused by camera movement.

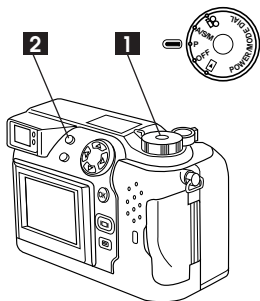
SELECTING THE FLASH MODE



1 Set the Mode dial to P or A/S/M.

2 With each press of the Flash mode button, the flash mode will switch from Auto-Flash to  (Red-Eye Reducing Flash, p. 59),  (Fill-In Flash, p. 60) and .

- The selected flash mode (except Auto-Flash) will appear on the control panel.

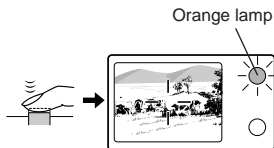

3 If the Orange lamp lights when the Shutter release button is pressed halfway, the flash is ready to fire.

Note:

- Unless OFF is selected in All Reset, the setting will be canceled and reset to Auto-Flash when the power is turned off. (p. 188)

SPOT METERING MODE

The Spot metering mode is used to obtain the right exposure regardless of the backlight. Place the subject in the center of the autofocus marks.

You can select the following modes with each press of the Spot/Macro button.

Digital ESP metering/Autofocus	
Spot metering mode	
Macro mode (p. 63)	
Macro mode + Spot metering mode (p. 64)	

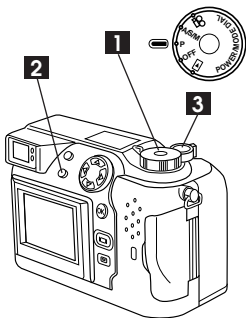

Control panel

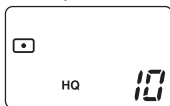

1 Set the Mode dial to P or A/S/M.

2 Press the Spot/Macro button until appears on the control panel.

- To cancel the Spot metering mode, press the Spot/Macro button several times until disappears.

3 Take a picture.

Note:

- Unless OFF is selected in All Reset, the setting will be canceled when the power is turned off. (p. 188)

MACRO MODE

You can get as close as 20 cm to your subject. An approx. 6 x 8 cm subject can be photographed almost fully within the frame.

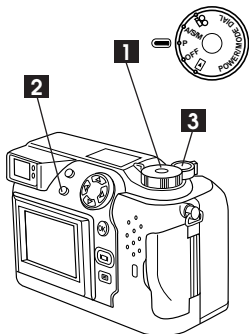

.....

1 Set the Mode dial to P or A/S/M.

2 Press the Spot/Macro button several times until  appears on the control panel.

- To cancel the Macro mode, press the Spot/Macro button several times until  disappears.

3 Take a picture.

Control panel

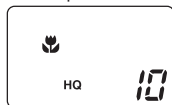

Shooting Range: Approx. 0.2 m ~ 0.8 m

Note:

- When using the flash in the Macro mode, the flash may not have the proper effect. Confirm the result using the LCD monitor.
- Using the LCD monitor as a viewfinder makes it easy to take close-up pictures.
- Unless OFF is selected in All Reset, the setting will be canceled when the power is turned off. (p. 188)

MACRO + SPOT METERING MODE

Use this mode when you want to use the Spot metering mode and your subject is closer than 0.8 m.

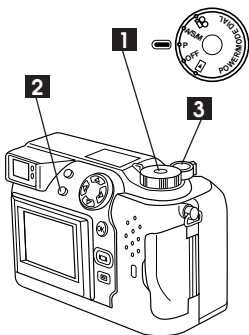

1 Set the Mode dial to P or A/S/M.

2 Press the Spot/Macro button several times until  appear on the control panel.

- To cancel the Macro + Spot metering mode, press the Spot/Macro button so that the icons disappear.

3 Take a picture.

Control panel

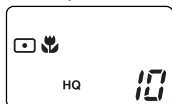

Note:

- Unless OFF is selected in All Reset, the setting will be canceled when the power is turned off. (p. 188)

MANUAL FOCUS

With Manual focus, you can select a pre-adjusted focal length. It is especially useful when quick shooting is required.

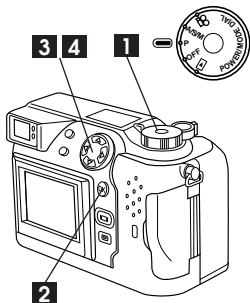

1 Set the Mode dial to P or A/S/M.

2 Press the OK button to display the focus mode selection screen on the LCD monitor.

3 Press the right arrow on the Jog dial to select MF.

- MF and the distance indicator appear on the control panel.
- To cancel, press the left arrow on the Jog dial to select AF. When MF disappears on the control panel, press the OK button.



Control panel

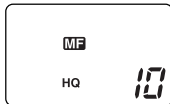

4 While looking at the LCD monitor, press the top/bottom arrows on the Jog dial to select the distance.

- The display will be enlarged to make focusing easy.

MANUAL FOCUS (Cont.)

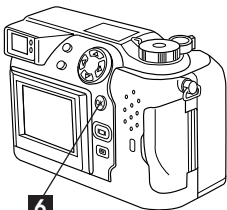
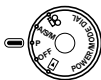

- 5** When the distance indicator is moved below 0.8 m, shorter distances will appear on the LCD monitor.

- 6** Press the OK button to save the setting.

















Note:

- The picture may become out of focus when the Zoom lever is pressed after Manual focus is selected. In such a case, readjust the distance using the Jog dial.
- Unless OFF is selected in All Reset, the setting will be canceled and reset to auto focus when the power is turned off. (p. 188)
- The distances on the LCD monitor are for reference only.
- When using the flash, shoot within the flash working range.

STILL PICTURE RECORD MENU

* Press the Menu button to set the following items when the Mode dial is set to A/S/M or P. (p. 38)

Monitor display	Use
 ↓	Using the Sequence mode (p. 68), Selftimer/Remote control (p. 70) or Auto bracket (p. 74).
 ↓	Selecting the white balance. (p. 76)
 ↓	Selecting the ISO sensitivity. (p. 78)
 ↓	Correcting the amount of light from the flash. (p. 80)
 ↓	Taking photographs of night views. (p. 82)
 ↓	Selecting the extension flash or main flash + extension flash. (p. 86)
 ↓	Using the Digital zoom mode. (p. 90)
 ↓	Using picture effects. (p. 92)
 ↓	Recording sound in the still picture recording mode. (p. 93)
 ↓	Taking panorama pictures or using with optional special function cards. (p. 95)
 ↓	Formatting the card. (p. 97)
 ↓	Making adjustments. [All reset (p. 188), Sharpness (p. 193), TIFF settings (p. 194), SQ settings (p. 196), Beep sound (p. 198), Full-time AF (p. 199), Rec view (p. 201), File number (p. 206), Brightness (p. 209), Date set (p. 28), Meters/feet (p. 211)]
 ↓	Selecting the recording mode (SQ/HQ/SHQ). (p. 99)
	Setting Aperture priority, Shutter priority or Manual mode for the Mode dial A/S/M. (p. 101)

SEQUENCE MODE

In the Sequence mode, the camera takes pictures sequentially while the Shutter release button is pressed. Sequential shooting at high shutter speeds (max. 3.1 frames/second) is possible in all modes except TIFF.

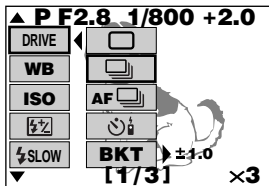
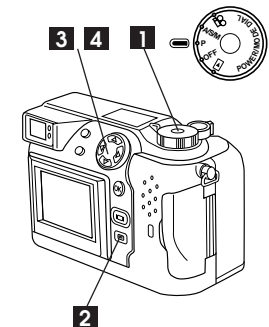

Control panel

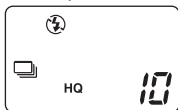





.....

1 Set the Mode dial to P or A/S/M.

2 Press the Menu button to display the Menu.

3 Press the top/bottom arrows on the Jog dial to select DRIVE.

4 Press the right arrow on the Jog dial, then press the top/bottom arrows to select  or AF .

-  appears on the control panel.
- When  is selected, the focus, exposure and white balance will be measured for the first frame.
- When AF  is selected, they will be measured for each frame.

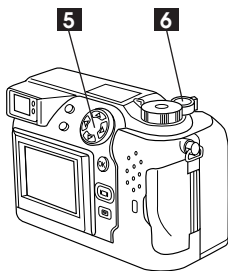

5 Press the left arrow on the Jog dial to confirm the setting.

6 If you take a picture without pressing the OK button, the setting will be valid until the Menu is canceled.

- Press the OK button to save the setting and cancel the Menu.
- Sequential shooting is possible up to 5 frames.

Note:

- The main flash cannot be used in the Sequence mode.
- When using an extension flash, set the speed fast enough to follow the sequential shooting.
- Since the LCD monitor's picture blacks out while taking pictures in the Sequence mode, use the viewfinder to take pictures in this mode.
- Unless OFF is selected in All Reset, the setting will be canceled when the power is turned off. (p. 188)
- This mode cannot be used in the TIFF recording mode.
- Since the slowest shutter speed in the Sequence mode is set to 1/30 second to prevent camera movement, the resulting picture may be darker than expected.
- Sequential shooting will continue for as long as the Shutter release button is held down. When the Shutter release button is released, Sequential shooting stops.
- Even if the Sequence mode is switched to another mode after taking sequential pictures, it will not be possible to take another picture until recording in the card finishes.
- The speed will be slower with AF .

SELFTIMER/REMOTE CONTROL

Use a tripod to hold the camera securely.

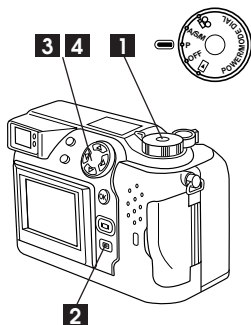



.....

1 Set the Mode dial to P or A/S/M.

2 Press the Menu button to display the Menu.

3 Press the top/bottom arrows on the Jog dial to select DRIVE.

4 Press the right arrow on the Jog dial, then press the top/bottom arrows to select .

-  appears on the control panel.

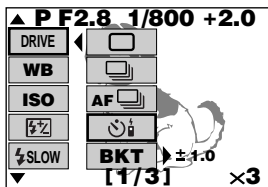

Control panel

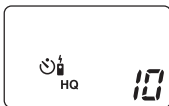

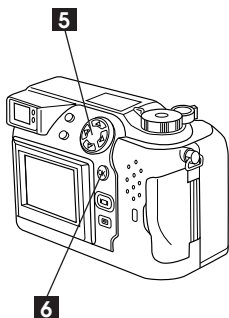

5 Press the left arrow on the Jog dial to confirm the setting.

6 Press the OK button to save the setting and cancel the Menu.

- Pictures can also be taken without pressing the OK button. (P. 72/73)

Note:

- Unless OFF is selected in All Reset, the setting will be canceled when the power is turned off. (p. 188)

SELFTIMER/REMOTE CONTROL (Cont.)

TAKING A PICTURE USING THE SELFTIMER

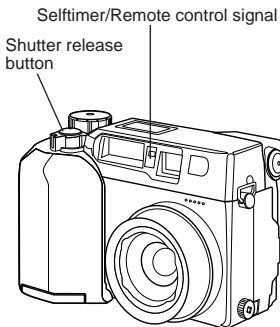

When the shutter is released, the Selftimer/Remote control signal lights for approx. 10 seconds then blinks for approx. 2 seconds before the picture is taken.

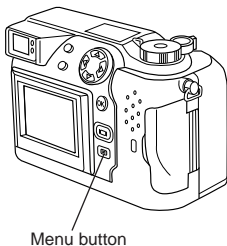

To stop the activated selftimer, press the Menu button.

Note:

- The Selftimer/Remote control mode will be canceled after a picture is taken using the Selftimer.

TAKING A PICTURE USING THE REMOTE CONTROL

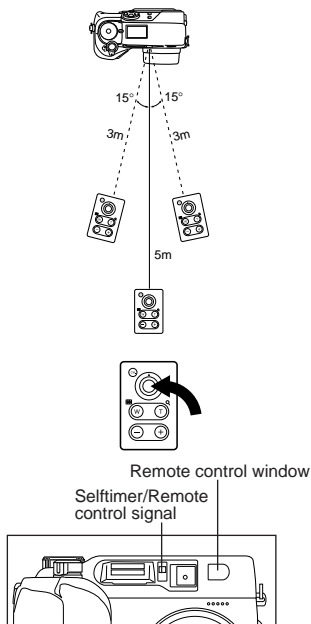

Compose the picture, aim the remote control at the Remote control window on the camera, then press the Shutter release button on the remote control to take a picture.

- The Selftimer/Remote control signal blinks for approx. 3 seconds before the picture is taken. If the signal does not blink when the Shutter release button is pressed, move closer to the camera and press it again. The signal does not light when there is frequency interference. In such a case, change the frequency according to the remote control instructions.
- See page 118 for using the Remote control in the Display mode.

Note:

- The Selftimer/Remote control mode will remain after a picture is taken using the Remote control.
- The working distance may be reduced in brightly lit areas, such as under direct sunlight.
- Do not subject the Remote control window to bright light.
- When the remote control is not operated for approx. 3 minutes, the Selftimer/Remote control mode will be canceled.

AUTO BRACKET

Images will be recorded sequentially with different exposures. You can select frames to store by erasing unwanted frames.

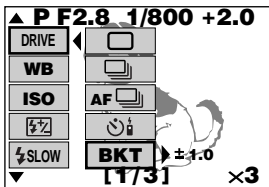
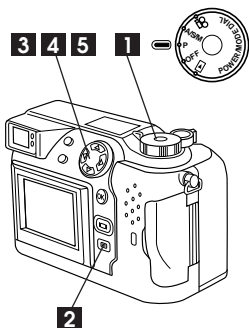

Control panel

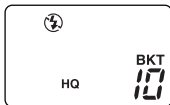

.....

1 Set the Mode dial to P or A/S/M .

- For A/S/M, the Shutter priority mode or Aperture priority mode must be selected. (p. 101)

2 Press the Menu button to display the Menu.

3 Press the top/bottom arrows on the Jog dial to select DRIVE.

4 Press the right arrow on the Jog dial, then press the top/bottom arrows to select BKT.

- BKT appears on the control panel.

5 Press the right arrow on the Jog dial, then press the top/bottom arrows to select the range.

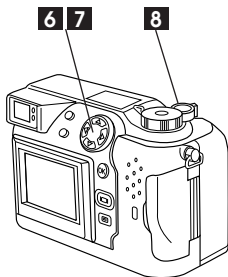

6 Press the right arrow on the Jog dial, then press the top/bottom arrows to select the number of pictures.

7 Press the left arrow on the Jog dial to confirm the setting.

8 If you take a picture without pressing the OK button, the setting will be valid until the Menu is canceled.

- Press the OK button to save the setting and cancel the Menu.

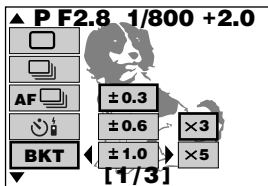

Note:

- The focus and white balance will be measured for the first frame.
- Not available in the Manual mode.
- The exposure level will be divided evenly within the selected range and the number of pictures.
- Unless OFF is selected in All Reset, the setting will be canceled when the power is turned off. (p. 188)
- This mode cannot be used in the TIFF recording mode.
- When the Shutter release button is released, picture taking finishes.
- If there is not enough room left in memory for the number of pictures taken with Bracketing, it will not be possible to take the next picture.

WHITE BALANCE

You can select the white balance according to the light source.

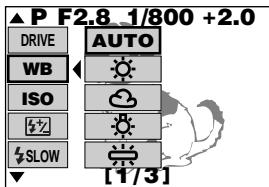
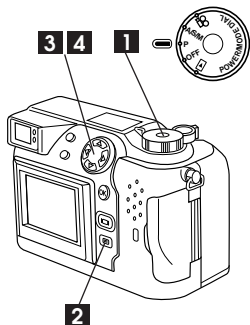

Control panel

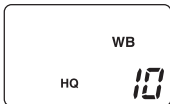

.....

1 Set the Mode dial to P or A/S/M.

2 Press the Menu button to display the Menu.

3 Press the top/bottom arrows on the Jog dial to select WB.

4 Press the right arrow on the Jog dial, then press the top/bottom arrows to select AUTO, ☀ (Daylight), ☁ (Overcast), ⚙ (Tungsten light) or ⚡ (Fluorescent).

- WB appears on the control panel when a setting other than AUTO is selected.

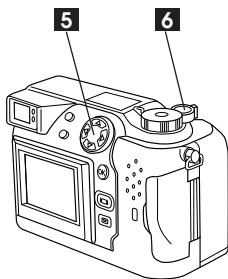

5 Press the left arrow on the Jog dial to confirm the setting.

6 If you take a picture without pressing the OK button, the setting will be valid until the Menu is canceled.

- Press the OK button to save the setting and cancel the Menu.

Note:

- Select AUTO in normal situations.
- The Manual white balance may not work under special lighting.
- Unless OFF is selected in All Reset, the setting will be canceled and reset to auto when the power is turned off. (p. 188)
- Confirm results in the Display mode.

ISO

You can select the sensitivity from AUTO, as well as approx. 100, 200 and 400.

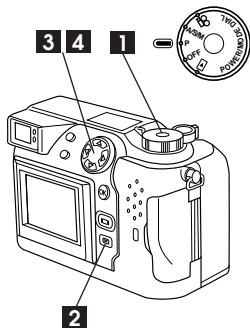

.....

1 Set the Mode dial to P.

2 Press the Menu button to display the Menu.

3 Press the top/bottom arrows on the Jog dial to select ISO.

4 Press the right arrow on the Jog dial, then press the top/bottom arrows to select the sensitivity.

- ISO appears on the control panel when a setting other than auto is selected.

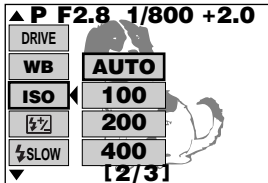

Control panel

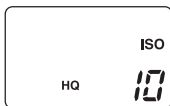

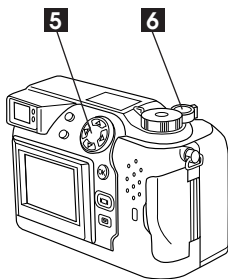

5 Press the left arrow on the Jog dial to confirm the setting.

6 If you take a picture without pressing the OK button, the setting will be valid until the Menu is canceled.

- Press the OK button to save the setting and cancel the Menu.
- With A/S/M, it is possible to select 100, 200 or 400.

Note:

- Unless OFF is selected in All Reset, the setting will be canceled and reset to auto when the power is turned off. (p. 188)
- When set to AUTO, it will be changed to 100 when the Mode dial is set to A/S/M.
- Pictures will appear grainy when the ISO is high.
- When AUTO is selected, the ISO is automatically set high in low-light situations when the flash is not used, to prevent blurring from camera movement.
- The sensitivity scale is based on the one used for picture film, but the numbers are for reference only.
- The higher the ISO, the faster the shutter speed that can be used and the lower the amount of light required.

FLASH CORRECTION

This corrects the amount of light emitted from the flash when it fires.

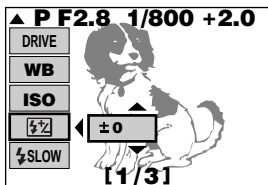
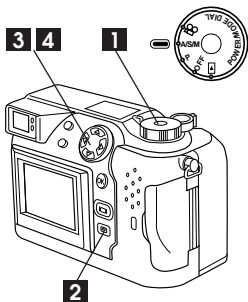

Control panel

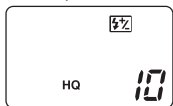

1 Set the Mode dial to P or A/S/M .

- For A/S/M, the Shutter priority mode or Aperture priority mode must be selected. (p. 101)

2 Press the Menu button to display the Menu.

3 Press the top/bottom arrows on the Jog dial to select ± 0 .

4 Press the right arrow on the Jog dial, then press the top/bottom arrows to select the amount of flash exposure correction.

- ± 0 appears on the control panel.
- Each time the top arrow is pressed, the exposure is corrected by a +1/3 EV step and each time the bottom arrow is pressed, the exposure is corrected by a -1/3 EV step. Correction can be made within a range of ± 2 EV.

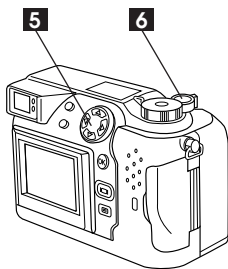

5 Press the left arrow on the Jog dial to confirm the setting.

6 If you take a picture without pressing the OK button, the setting will be valid until the Menu is canceled.

- Press the OK button to save the setting and cancel the Menu.

Note:

- If the FL-40 extension flash is set to TTL-AUTO and it is used simultaneously with the main flash, correction is made for the amount of light emitted from both flashes.
- If the FL-40 extension flash is set to MANUAL and it is used simultaneously with the main flash, correction is made only for the amount of light emitted by the main flash.
- If the shutter speed is fast, the resulting flash light correction effect may not be sufficient.

SLOW SHUTTER SYNCHRONIZATION FLASH MODE

You can set the flash to fire during the first or second half of a slow shutter speed's release duration. It is especially great for taking photographs of night views.

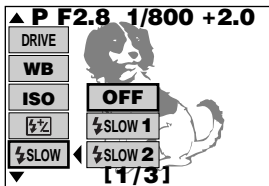
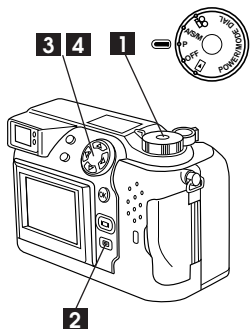

Control panel

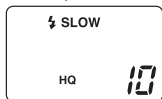

1 Set the Mode dial to P or A/S/M.

2 Press the Menu button to display the Menu.

3 Press the top/bottom arrows on the Jog dial to select SLOW .

4 Press the right arrow on the Jog dial, then press the top/bottom arrows to select 1 or 2.

- SLOW appears on the control panel.
- Select 1 for capturing images at the beginning of the shutter release duration. The taillights of a moving car will have a forward streak.
- Select 2 for capturing images at the end of the shutter release duration. The taillights of a moving car will have a receding streak.
- When 2 is selected, the flash will fire a pre-flash before the regular flash.

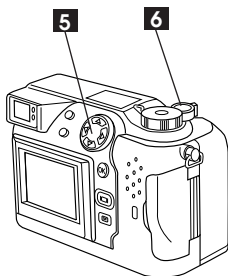

5 Press the left arrow on the Jog dial to confirm the setting.

6 If you take a picture without pressing the OK button, the setting will be valid until the Menu is canceled.

- Press the OK button to save the setting and cancel the Menu.

Note:

- This mode can be used with both the main flash and an extension flash.
- Unless OFF is selected in All Reset, the setting will be canceled and reset to off when the power is turned off. (p. 188)

EXTENSION FLASH PHOTOGRAPHY

The FL-40 extension flash (optional) can be used to take various kinds of flash photographs, either by itself or together with the main flash. To connect the extension flash to the camera, the exclusive grip (optional) and bracket cable (optional) are required.

TAKING PHOTOGRAPHS USING THE FL-40 EXTENSION FLASH

If the extension flash is used, the flash mode and exposure compensation are detected automatically, allowing the main flash and extension flash to function together.

Using the two flashes together enables more sophisticated lighting, such as using the extension flash for bounce lighting and the main flash for front lighting. The default setting is to have the extension flash and main flash work together.

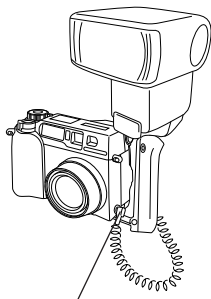

Extension flash connection terminal

.....

1 Mount the FL-40 extension flash on the exclusive grip, then fasten it to the camera's tripod hole and connect the exclusive grip and the camera's extension flash connection terminal using the exclusive bracket cable.

- The extension flash connector cover on the camera is a screw type. Unscrew and remove it to connect the exclusive bracket cable.

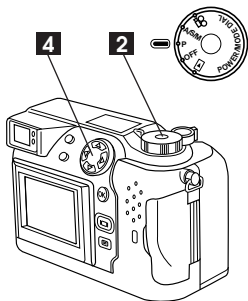

2 Set the camera's mode dial to P or A/S/M.

- With A/S/M, the LCD monitor will turn on automatically.

3 Turn on the extension flash unit's power.

- The extension flash is set to the TTL-AUTO mode.

4 Select the camera's flash mode.

- Auto-Flash, Red-Eye Reducing Flash, Fill-In Flash and Off modes are available. (p. 58)

Note:

- Slow synchro can be set. (p. 82)
- When taking close-up pictures, they may be overexposed. Use the main flash.
- If both the main flash and the FL-40 are used for flash photography, the main flash is used as the compensating light source, so if the amount of light from the FL-40 is insufficient (beyond its working range), the photo may be underexposed.

EXTENSION FLASH PHOTOGRAPHY (Cont.)

TAKING PHOTOGRAPHS WITH THE FL-40 EXTENSION FLASH ONLY

You can use the extension flash only or use the main flash and extension flash together. If you are using the extension flash, the main flash can be set so that it will not fire in order to prevent the camera's batteries from running down.

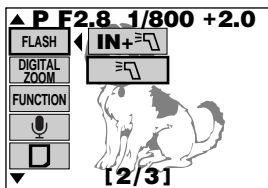
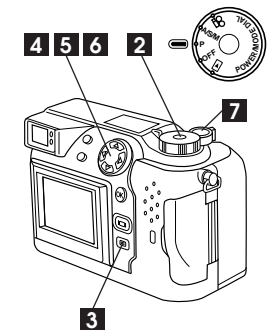

- 1** Mount the FL-40 extension flash on the exclusive grip, then fasten it to the camera's tripod hole and connect the exclusive bracket cable to the camera's extension flash connection terminal.
- 2** Set the camera's mode dial to P, or A/S/M.
 - With A/S/M, the LCD monitor will turn on automatically.
- 3** Press the Menu button to display the Menu.
- 4** Press the top/bottom arrows on the Jog dial to select FLASH.
- 5** Pressing the right arrow on the Jog dial, then press the top/bottom arrows to select .
- 6** Press the left arrow on the Jog dial to confirm the setting.

7 If a picture is taken without pressing the OK button, the setting will remain in effect until the Menu button is pressed again.

- Press the OK button to save the setting and cancel the Menu.

Note:

- Unless OFF is selected in All Reset, the setting will be canceled and reset to the default when the power is turned off. (p. 188)
- The extension flash may occasionally fire by mistake.
- Be sure to use the exclusive grip and bracket cable to make connections between the FL-40 and the camera. If another method is used, the FL-40 will only function as an ordinary extension flash.

TAKING PHOTOGRAPHS WITH ANOTHER BRAND OF EXTENSION FLASH

Another brand of extension flash can also be used with the exclusive grip and bracket cable. However, it can only be operated in the Auto mode.

For details about the conditions in which an extension flash may be used, see "Other brands of extension flash that can be used". (p. 89)

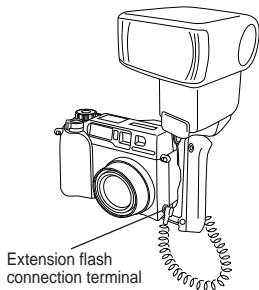

1 Mount the extension flash on the exclusive grip, then fasten it to the camera's tripod hole and connect the exclusive bracket cable to the camera's extension flash connection terminal.

EXTENSION FLASH PHOTOGRAPHY (Cont.)

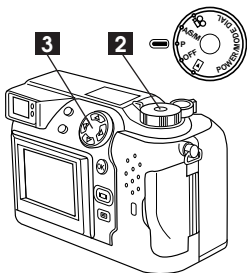

2 Set the camera's Mode dial to A/S/M.

- The LCD monitor turns on automatically.

3 In the Menu screen, set the A/S/M mode to A (Aperture priority mode) or M (Manual mode). (p. 101)

4 Turn the extension flash unit's power on.

5 Set the Light Adjustment mode for the extension flash unit. For more details, see the user's manual for the flash unit.

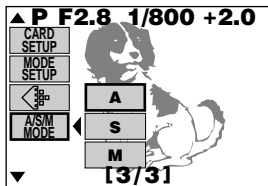

Note:

- If you are using another brand of extension flash, it cannot be used without the main flash.
- The camera's flash mode has no effect on the extension flash. It will fire even when the camera's flash mode is set to Off.
- Before using another brand of flash unit, take care concerning the following points.
 - Some flashes available on the market operate with a high voltage synchro terminal. If such a flash unit is used, it may not function normally. Contact the manufacturer of the flash you are using concerning the specifications of the flash's synchro terminal.
 - Some flashes available on the market have the polarity of the synchro terminals reversed. In this case, even if the flash is connected, it will not fire. Contact the manufacturer of the flash for more information.
- Confirm in advance that the flash unit you are using is synchronized with the camera.
- If a flash unit or other accessory with additional communications functions is used, it may not only fail to function normally, but may also cause damage to the camera's circuitry. Do not use such a device.
- It is recommended that the Olympus FL-40 extension flash be used with this camera.

Other brands of extension flash that can be used.

When selecting an extension flash, use products which meet the following basic conditions.

- (1) Exposures when using an extension flash require that adjustments be made on the extension flash unit.
If an extension flash is used in the Auto mode, matched it with the F value and ISO sensitivity settings on the camera.
- (2) Even if the auto F value and ISO sensitivity of the extension flash are set to the same conditions as those on the camera, depending on the photographic conditions, it is possible that the correct exposure may not be obtained anyway. In such a case, adjust the auto F value or ISO value on extension flash unit or calculate the distance in the manual mode and use it that way. However, generally, the auto F value and ISO value can only be adjusted 1 step and beyond that, exposure compensation cannot be made. (Exposure compensation in the camera is made invalid in extension flash photography.)
- (3) Use a flash which is capable of covering an illumination angle for a 35 mm or larger lens when calculated for 32 mm film. However, in close-up photography with the lens on the wide setting, the bottom of the image may not expose correctly. The ideal is to have a wide angle adapter to fit on the flash and spread the illumination angle so it is wider.
- (4) Use a flash unit with a flash time of 1/200 sec. or less when using the flash at full strength. For devices with a long flash time, such as a ring flash, a portion of the light emitted will not contribute to the exposure.
- (5) If a flash unit or other accessory with additional communications functions other than the FL-40 is used, it may not only fail to function normally, but may also cause damage to the camera's circuitry. Do not use such a device.

DIGITAL ZOOM MODE

When used with the 3X optical zoom, you can take an approx. 7.5X zoom photograph.

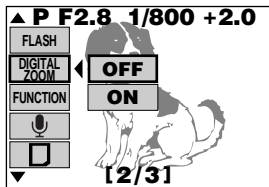
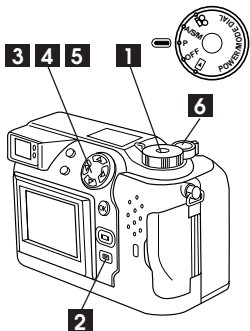

- 1** Set the Mode dial to P or A/S/M.
 - When P is selected, press the LCD monitor ON/OFF button to turn on the LCD monitor.
- 2** Press the Menu button to display the Menu.
- 3** Press the top/bottom arrows on the Jog dial to select DIGITAL ZOOM.
- 4** Press the right arrow on the Jog dial, then press the top/bottom arrows to select ON.
- 5** Press the left arrow on the Jog dial to confirm the setting.
- 6** If you take a picture without pressing the OK button, the setting will be valid until the Menu is canceled.
 - Press the OK button to save the setting and cancel the Menu.

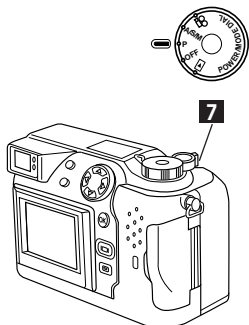

7 Turn the zoom lever toward T to display an enlarged subject.

- The zoom bar will be displayed on the LCD monitor. The white area of the bar indicates optical zoom, and the red area indicates digital zoom.
- The mode is canceled when the LCD monitor is turned off.



Note:

- Unless OFF is selected in All Reset, the setting will be canceled and reset to 1X when the power is turned off. (p. 188)
- The setting will be canceled and reset to 1X when the LCD monitor is turned off.
- Images may be grainy in this mode.

PICTURE EFFECTS

You can select from four picture effects.

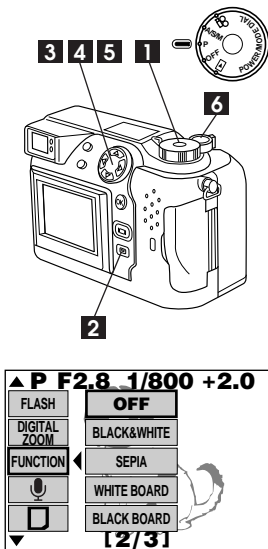

.....

1 Set the Mode dial to P or A/S/M.

2 Press the Menu button to display the Menu.

3 Press the top/bottom arrows on the Jog dial to select FUNCTION.

4 Press the right arrow on the Jog dial, then press the top/bottom arrows to select the desired picture effect.

5 Press the left arrow on the Jog dial to confirm the setting.

6 If you take a picture without pressing the OK button, the setting will be valid until the Menu is canceled.

- Press the OK button to save the setting and cancel the Menu.
- The LCD monitor stays on while recording with picture effects.

Note:

- When letters cannot be recorded clearly with WHITE BOARD or BLACK BOARD selected, use exposure compensation. (p. 57)
- Unless OFF is selected in All Reset, the setting will be canceled and reset to off when the power is turned off. (p. 188)
- When the Mode dial is set to , WHITE BOARD and BLACK BOARD will be reset to off.

SOUND RECORD MODE

You can record sound after shooting a picture. Sound can be recorded for 4 seconds per picture.

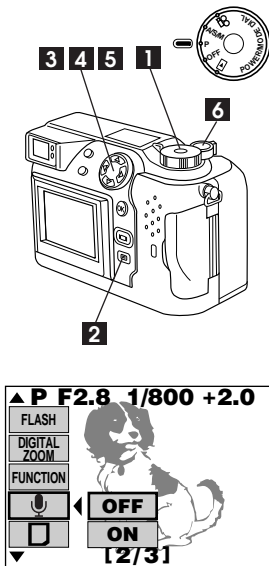

.....

1 Set the Mode dial to P or A/S/M.

2 Press the Menu button to display the Menu.

3 Press the top/bottom arrows on the Jog dial to select .

4 Press the right arrow on the Jog dial, then press the top/bottom arrows to select ON.

-  appears on the control panel.

5 Press the left arrow on the Jog dial to confirm the setting.

6 If you take a picture without pressing the OK button, the setting will be valid until the Menu is canceled.

- Press the OK button to save the setting and cancel the Menu.

SOUND RECORD MODE (Cont.)

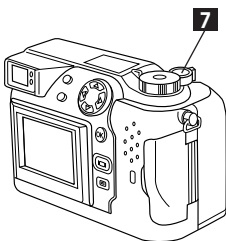

7 Shoot a subject.

- Sound recording will start approximately 0.5 second after the shutter button is pressed. While recording sound, the green lamp and the record mark displayed on the control panel will flash, and a bar will be displayed on the LCD monitor.

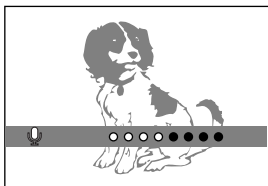

Control panel

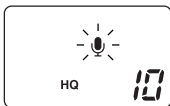



Note:

- Sound cannot be recorded with a picture shot in the TIFF mode, but it can be added later during playback.
- You can record sound with a recorded still picture afterwards. (p. 112)
- Sound recording will start after the picture is taken but before it is recorded in the card. After shooting, confirm the display of the LCD monitor and the control panel, and keep the camera's microphone (p. 18) directed at the subject from whom you want to record sound.
- The sound may not be recorded clearly if there is a distance of 1 m or more between subject and camera.
- It is not possible to take pictures during sound recording.

PANORAMA MODE

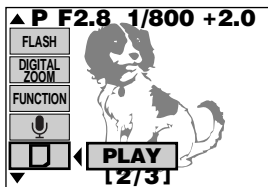
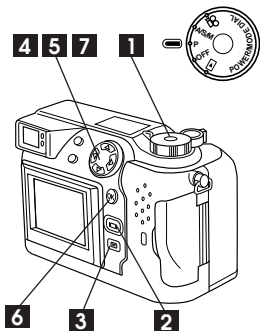
You can make panorama pictures.



- 1** Set the Mode dial to P.
- 2** Press the LCD monitor ON/OFF button to turn on the LCD monitor.
- 3** Press the Menu button to display the Menu.
- 4** Press the top/bottom arrows on the Jog dial to select .
- 5** Press the right arrow on the Jog dial to select PLAY.
- 6** Press the OK button.
- 7** Select the connecting direction (right, left, up, down) using the Jog dial.

PANORAMA MODE (Cont.)

- 8** Take pictures by overlapping the edges of the images.

- A maximum of 10 images can be connected.

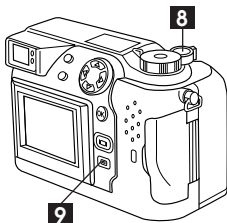
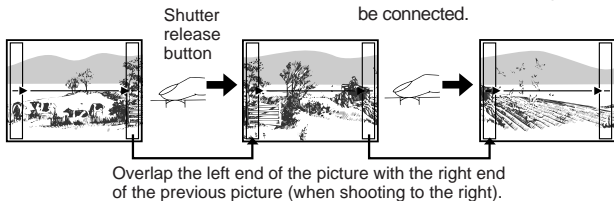

- 9** Press the Menu button to cancel the Panorama mode and Menu.

Note:

- The Panorama mode is available only when an Olympus brand Standard memory card is used.
- Turn on the LCD monitor before pressing the Menu button in order to select the Panorama mode.
- Do not move the Zoom lever after shooting the first picture to avoid problems with picture assembly.
- The flash cannot be used in the Panorama mode.
- Because the focus, the exposure, and the white balance are determined by the first picture, do not shoot overly bright/dark subjects such as the sun in the first frame.
- Use of the SQ mode is recommended to save memory.
- Panorama images must be assembled on a computer. Follow directions carefully for the supplied panorama application to successfully assemble panorama images.
- When a picture is taken in the TIFF (non-compression) recording mode, it will be recorded in the SHQ (JPEG) mode.

CARD SETUP (CARD FORMAT)

You can format the card.

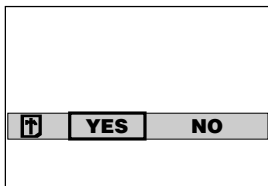
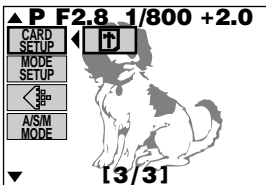
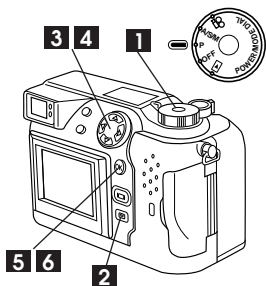

.....

1 Set the Mode dial to P or A/S/M.

2 Press the Menu button to display the Menu.

3 Press the top/bottom arrows on the Jog dial to select CARD SETUP.

4 Press the right arrow on the Jog dial to select [T].

5 Press the OK button to display [T] YES NO .

6 Press the OK button again with YES selected to format the card.

- To cancel, select NO using the right arrow on the Jog dial and press the OK button.

CARD SETUP (CARD FORMAT) (Cont.)

Note:

- Formatting the card erases the existing data, including pictures which have been write-protected from the camera. Be careful not to erase important data when formatting a recorded card.
- Formatting will not be engaged when the write-protect adhesive seal is placed on the card.
- Non-Olympus brand cards or cards formatted from or used in a computer must be formatted by the camera. These cards may take longer to record than recommended Olympus brand cards.
- It is highly recommended that you confirm the contents before formatting.

SELECTING THE RECORDING MODE

There are 5 different image quality settings to select from: TIFF, SHQ, SQ1 and SQ2.

The image quality becomes higher in the order of SQ2 → SQ1 → HQ → SHQ → TIFF.

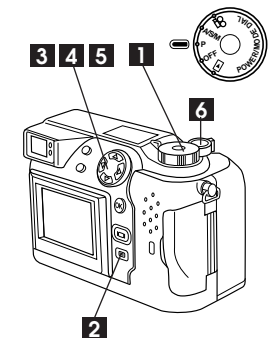

1 Set the Mode dial to P or A/S/M.

2 Press the Menu button to display the Menu.

3 Press the top/bottom arrows on the Jog dial and select .

4 Press the right arrow on the Jog dial, then press the top/bottom arrows to select the recording mode.

- The selected recording mode appears on the control panel.

5 Press the left arrow on the Jog dial to confirm the setting.

- The recording size can be selected for TIFF, SQ1 and SQ2. (p. 194 ~ 197)

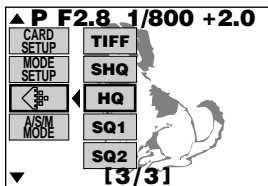

Control panel

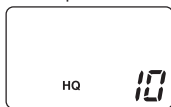

SELECTING THE RECORDING MODE (Cont.)

6 If you take a picture without pressing the OK button, the setting will be valid until the Menu is canceled.

- Press the OK button to save the setting and cancel the Menu.

Default resolution and compression rate settings.

Recording mode	TIFF	SHQ	HQ
Resolution	2048 x 1536		
Compression	Uncompressed	Low-Compression JPEG	Standard JPEG

Recording mode	SQ1	SQ2
Resolution	1280 x 960	640 x 480
Compression	Standard JPEG	

Note:

- Unless OFF is selected in All Reset, the setting will be canceled when the power is turned off. (p. 188)
- When the Mode dial is set to , the recording mode will change to HQ.
- The lower the compression rate, the better the image quality when the picture is enlarged. Also, compared to SQ1, SQ2 and HQ, the recording time for SHQ and TIFF is longer.
- The number of storable pictures varies according to the recording mode. TIFF requires more room in the card than other modes. (p. 36)

A/S/M MODE

You can select Aperture priority mode, Shutter priority mode or Manual mode for A/S/M on the Mode dial.

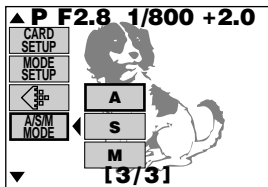
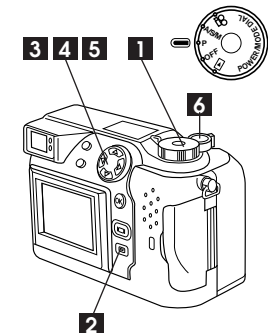

.....

1 Set the Mode dial to P or A/S/M.

2 Press the Menu button to display the Menu.

3 Press the top/bottom arrows on the Jog dial to select A/S/M MODE.

4 Press the right arrow on the Jog dial, then press the top/bottom arrows to select A (Aperture priority), S (Shutter priority) or M (Manual).

- Refer to the respective page for each function.

5 Press the left arrow on the Jog dial to confirm the setting.

6 If you take a picture without pressing the OK button, the setting will be valid until the Menu is canceled.

- Press the OK button to save the setting and cancel the Menu.

Note:

- Unless OFF is selected in All Reset, the setting will be canceled when the power is turned off. (p. 188)

DISPLAYING RECORDED PICTURES

You can display the pictures you have taken on the LCD monitor.

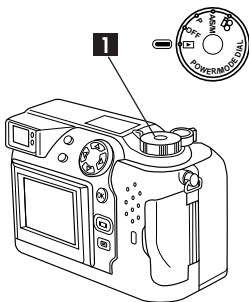

1 Set the Mode dial to . The LCD monitor turns on automatically.

- When the power is turned on in the Display mode, a card check is executed automatically. When a card is not inserted, or there is some trouble with the card, the card error indicator blinks on the control panel.
- When a card in a different format is inserted, the camera automatically enters the Card format mode. (p. 196)

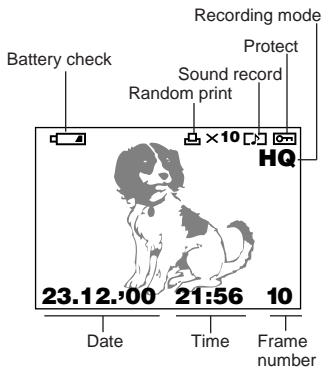

2 The last picture taken is displayed.

- When there are no pictures stored in the card, NO PICTURE will appear.
- The last picture taken, Frame number, Recording mode, and Battery check indicator will appear on the LCD monitor for 5 seconds. The Date, Print and Protect indicator will also appear if they are set.
- If the battery power is low, the Battery check indicator will light in red.
-  will appear for a movie picture, which can be displayed as a movie. (p. 146)

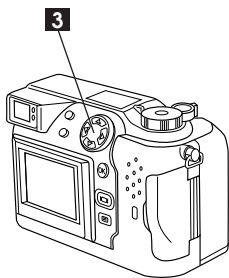

- 3** With each press of the right arrow on the Jog dial, you can view the succeeding picture. With each press of the left arrow, you can view the preceding picture.

[10-frame jump using the Jog dial]

- With each press of the bottom arrow, you can view the picture 10 frames ahead.
- With each press of the top arrow, you can view the picture 10 frames behind.

Note:

- Information recorded when the picture was taken (camera settings, date and time, file name, etc.) can also be displayed. (p. 110)
- Do not push the LCD monitor forcibly.
- When turned on, the LCD monitor flashes, and pictures appear in about 0.5 ~ 2 seconds. This is not a malfunction.
- Sound cannot be played back on this camera. Connect it to a TV for sound playback. (P. 118)

DISPLAYING RECORDED PICTURES (Cont.)

INDEX-DISPLAY MODE

Multiple pictures can be displayed on the LCD monitor.

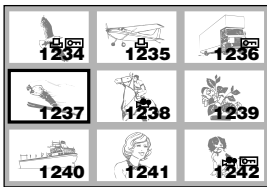
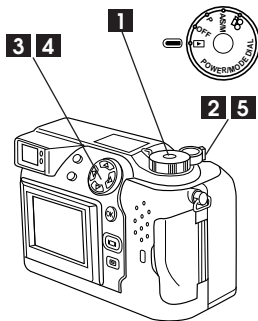

- 1 Set the Mode dial to .
- 2 Press the Zoom lever toward W to display several pictures on the monitor.
 - It may take approx.1 second before the picture is displayed.
- 3 Press the right arrow on the Jog dial to select succeeding pictures. Press the left arrow on the Jog dial to select preceding pictures.
- 4 Press the bottom arrow on the Jog dial to select the succeeding group of pictures. Press the top arrow on the Jog dial to select the preceding group of pictures.
- 5 Press the Zoom lever toward T to display the currently selected picture in one frame.

Note:

- The number of frames can be selected from 4, 9 or 16. (p. 212)

CLOSE-UP DISPLAY MODE (3X INSPECTION)

Enlarged pictures can be displayed on the LCD monitor.

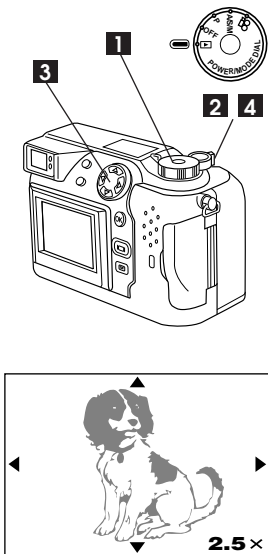

.....

1 Set the Mode dial to , and display the picture you want to enlarge.

2 With each press of the Zoom lever toward T, the picture is enlarged 1.5X, 2X, 2.5X, and 3X.

- Pressing the Zoom lever toward W returns to 1X.

3 Use the Jog dial to select the section of the picture to view.

4 To select another picture, press the Zoom lever toward W to return to 1X, then display the desired picture. (P. 103).

PROTECTION

You can prevent accidental erasure of pictures you want to keep.

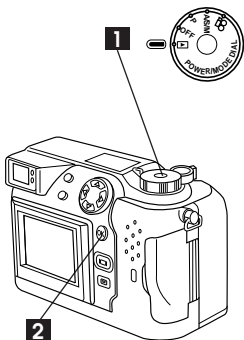

1 Set the Mode dial to , and display the picture you want to protect.

2 Press the OK button.

-  appears on the LCD monitor.
- To cancel protection, press the OK button again while the picture is displayed.
- Protection setting/canceling are also available in the Index-Display mode (p. 104) and the Close-Up display mode (p. 105).

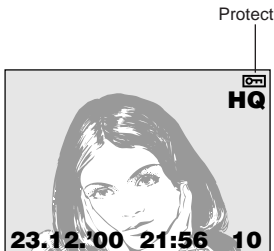







Note:

- The protected picture will not be deleted with All-Frame erase, but will be deleted with Card format.
- Protection is not available when the write-protect adhesive seal is placed on the card.
- The setting will remain until it is readjusted.

STILL PICTURE DISPLAY MENU

* Press the Menu button to set the following items when the Mode dial is set to  and a still picture is displayed on the LCD monitor.

Monitor display	Use
 ↓	Slide-show display. (p. 109)
 ↓	Displaying information (camera settings, date and time, file name, etc.) about the image. (p. 110)
 ↓	Adding sound to images which have already been photographed. (p. 112)
 ↓	Use with optional Olympus special function SmartMedia cards (template).
 ↓	Erasing all frames (p. 114) or formatting a card. (p. 116)
 ↓	Making adjustments. [All reset (p.188), Beep sound (p. 198), Index-Display adjustment (p. 212), Brightness (p 209), Date/time set (p. 28)]

PICTURE INFORMATION

You can display picture information (settings, date/time, file number, etc.) on the LCD monitor.

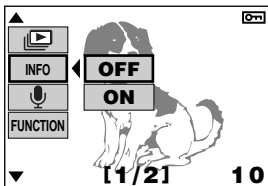
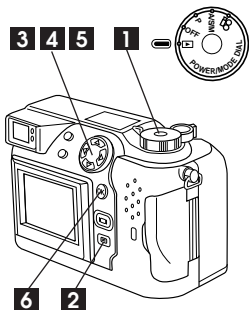

.....

1 Set the Mode dial to , and display a still picture.

2 Press the Menu button to display the Menu.

3 Press the top/bottom arrows on the Jog dial to select INFO.

- To cancel, press the Menu button.

4 Press the right arrow on the Jog dial, then select ON using the top/bottom arrows.

5 Press the left arrow on the Jog dial to confirm the setting.

6 Press the OK button to save the setting and cancel the Menu.

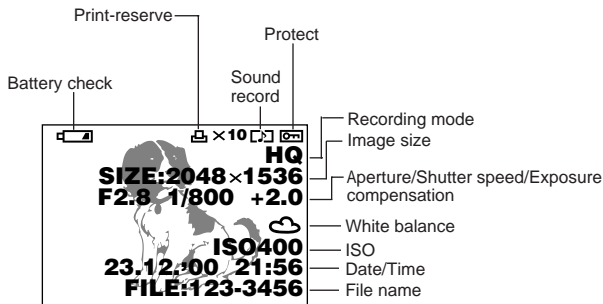

Note:

- When picture information is displayed, the frame number will not be displayed.
- Unless OFF is selected in All Reset, the setting will be canceled when the power is turned off. (p. 188)
- The information is displayed for a period of 5 seconds.

RECORDING SOUND

Sound can be added to images which have already been recorded, or it can be re-recorded over previous sound.

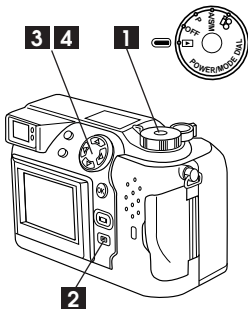

.....

1 Set the Mode dial to , and display a still picture.

2 Press the Menu button to display the Menu.

3 Press the top/bottom arrows on the Jog dial to select  .

- Press the Menu button to cancel.

4 Press the right arrow on the Jog dial to select START.

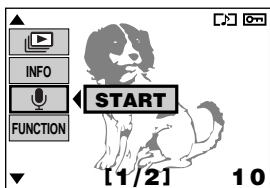

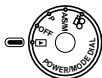

- 5** Press the OK button to start recording. About 4 seconds of sound is recorded. A progress bar will be displayed on the LCD monitor.

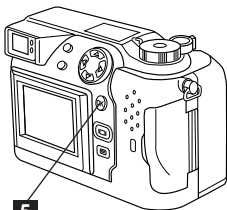

5

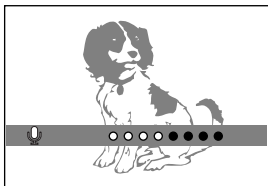

Note:

- A card with a write-protect adhesive seal affixed to it cannot be recorded on.
- If there is very little space remaining on a card, it may be impossible to record on it.
- If the sound for an image is recorded over, the previous sound is erased and only the new sound is recorded.
- The sound may not be recorded clearly if there is a distance of 1 m or more between subject and camera.
- Sound cannot be added to protected images.

CARD SETUP

ALL-FRAME ERASE

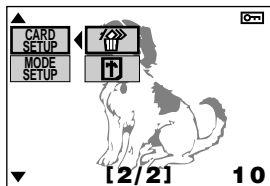
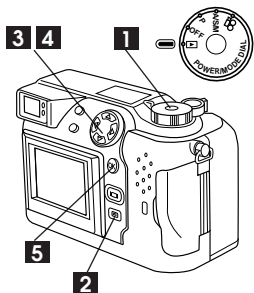

.....

1 Set the Mode dial to , and display a still picture.

2 Press the Menu button to display the Menu.

3 Press the top/bottom arrows on the Jog dial to select CARD SETUP.

4 Press the right arrow on the Jog dial, then press the top/bottom arrows to select  .

5 Press the OK button to display  YES NO .

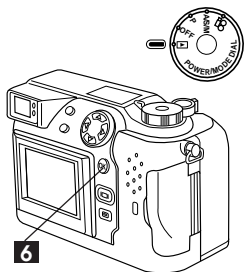

6 Press the OK button with **YES** selected to erase all the pictures in the card.

- To cancel, select **NO** using the right arrow on the jog dial and press the OK button.

7 When complete, **NO PICTURE** appears on the LCD monitor.

- Protected frames will remain in the card, and the last frame will be displayed. (p. 106)

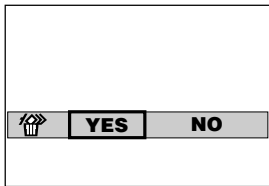

Caution:



- The time it takes to erase differs depending on the number of recorded images.
- Be careful not to erase important picture data by mistake as it cannot be retrieved.
- Never open the card cover, eject the card, remove the batteries, or pull the plug while erasing pictures. It may destroy the data in the card.
- When a write-protect adhesive seal is placed on the card, the camera does not enter the Erase mode.

CARD SETUP (Cont.)

CARD FORMAT

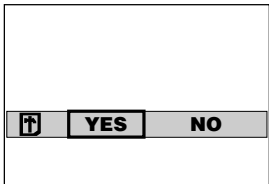
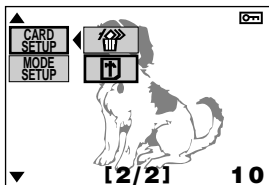
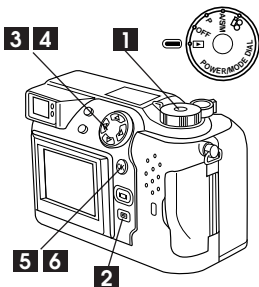
You can format the card.



- 1 Set the Mode dial to , and display a still picture.
- 2 Press the Menu button to display the Menu.
- 3 Press the top/bottom arrows on the Jog dial to select CARD SETUP.
- 4 Press the right arrow on the Jog dial, then press the top/bottom arrows to select .
- 5 Press the OK button to display  YES NO .
- 6 Press the OK button again with YES selected to format the card.
 - To cancel, select NO using the right arrow on the Jog dial and press the OK button.
- 7 When complete, NO PICTURE appears on the LCD monitor.

Note:

- Formatting the card erases the existing data, including pictures which have been write-protected from the camera. Be careful not to erase important data when formatting a recorded card.
- Formatting will not be engaged when the write-protect adhesive seal is placed on the card.
- Non-Olympus brand cards or cards formatted from or used in a computer must be formatted by the camera. These cards may take longer to record than recommended Olympus brand cards.
- It is highly recommended that you confirm the contents before formatting.

CONNECTING TO A TELEVISION

Recorded images can be viewed on a TV. If sound is recorded with the image, it will be played as well.

Make sure that the power of the TV and the camera are off before connecting.

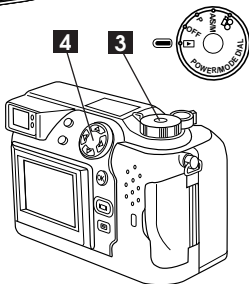
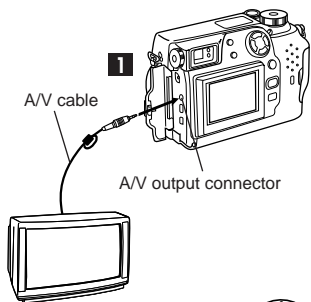

1 Connect the AV cable to the camera's A/V output connector, then connect it to the TV's audio (white) and video (yellow) input connectors.

2 Turn on the TV.

3 Set the Mode dial to .

4 Select a picture using the Jog dial.

[When using the remote control]

Aim the remote control at the Remote control window on the camera. Press the +/- buttons to select a picture. Press the W button for Index-Display. Press the T button for Close-Up display, and select the section to view with the +/- buttons.

Note:

- The LCD monitor turns off automatically when connected to a TV.
- Refer to your TV/VCR instruction manual for information about displaying video images.
- The picture may appear to be off-center on the TV screen because of the TV adjustment.
- Your TV may produce a black frame around the picture, which may look peculiar when printed to a video printer.
- The use of the optional AC adapter is recommended.
- Images shown on screen can be saved to a video tape.



3

MOVIE FUNCTIONS

- You can record movies for up to approx. 218 seconds in the SQ mode and approx. 55 seconds in the HQ mode when a 16MB card is used.
- The recorded movie images will be stored as a Motion JPEG file.
- You can observe the images in the Display mode.
- Sound is recorded with the movie.

RECORDING MOVIES

RECORDING MOVIES USING THE LCD MONITOR

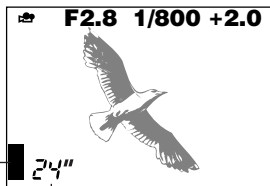
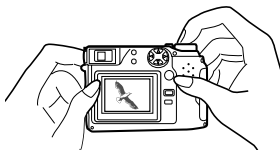
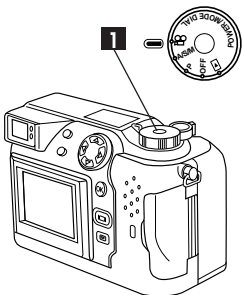

Seconds remaining

Image memory blocks



1 Set the Mode dial to .

2 Compose the picture using the LCD monitor.

Press the Shutter release button halfway. The exposure and focus are locked and the green lamp next to the viewfinder lights.

- Also refer to AUTOFOCUS (p. 48).

3 Press the Shutter release button fully. Recording starts. To end recording, press the Shutter release button fully again.

- The seconds remaining appear on the LCD monitor.
- The lower image memory block will light and the camera will start storing the image in the card.
- Unless the card is full, the next movie can be recorded even while the image is being stored, until all of the blocks light.



4 When the buffer memory is full, the upper block will light and no other operation can be performed until the upper block goes off.

- When CHECK is selected in REC VIEW in MODE SETUP the Save confirmation screen will let you choose whether or not to store the movie in the card. (p. 202)

Note:

- If the recorded movie is a long one, no image may appear for a while on the LCD monitor during the REC VIEW function. This is not a malfunction.
- During movie recording, focus is fixed at the point where focus is locked. If your subjects are at different distances, stop recording and focus on the objects again.
- Only Digital zoom is available during movie recording. Because the image in the viewfinder is not affected by Digital zoom, use the LCD monitor to check results.
- The image quality is lower compared with a still photo.
- Do not push the LCD monitor forcibly.
- Pictures that appear on the LCD monitor are for composition purposes only.
- When the subject is viewed diagonally in the camera, the edges may appear zigzagged on the LCD monitor. This is not a malfunction; it will be less noticeable in Display mode.
- A strip of light may appear on the top/bottom of the LCD monitor, but this is not a malfunction.
- When a picture is taken in a lighted area, such as in sunlight, vertical lines may appear on the LCD monitor. This is not a malfunction.
- Printed images will be slightly cropped compared with what you see on the LCD monitor.

RECORDING MOVIES (Cont.)

QUICK VIEW

You can immediately shift from the Record Mode to the Display mode, and check the movie you have just recorded.

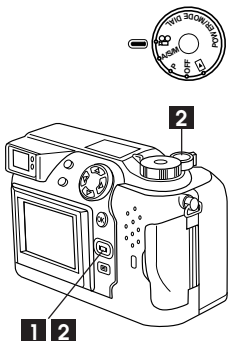

.....

1 When the Mode dial is set to , quickly press the LCD monitor ON/OFF button twice.

- The LCD monitor will display the last movie recorded. (p. 145 ~ 157)

2 To return to the Record Mode, press the LCD monitor ON/OFF button or the Shutter release button.

FOCUS LOCK

If your main subject is not within the autofocus marks, follow the procedure below to obtain focus. This is called focus lock.

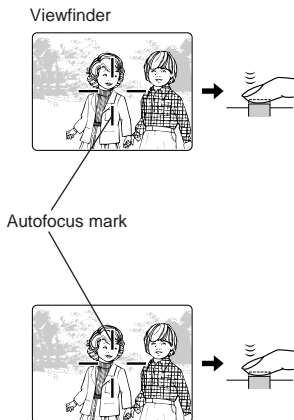

.....

1 Position your subject within the autofocus marks, and press the Shutter release button halfway.

- The Green lamp next to the viewfinder lights.

2 Recompose the picture while keeping the Shutter release button pressed halfway.

3 Press the Shutter release button fully to start recording.

Note:

- The autofocus mark does not appear on the LCD monitor. Confirm that the subject is centered and in focus before taking the picture.
- If the Green lamp blinks, the focus or exposure is not locked.

WORKING RANGE

Record movies at a distance between 0.2 m ~ ∞ .

- Subjects closer than 0.2 m may turn out to be out of focus and incorrectly exposed.
- Using the LCD monitor as a viewfinder makes it easy to record close-ups.
- Power consumption increases when the LCD monitor is used.

Working range

Macro mode	0.2 m ~ 0.8 m
Standard mode	0.8 m ~ ∞

ZOOM

You can select Telephoto or Wide-angle. Only Digital zoom is available during movie recording. Because the image in the viewfinder is not affected by zoom lever operation, use the LCD monitor to check images that have been zoomed-in or -out.

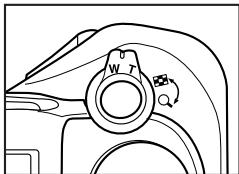

Press the lever toward T to zoom in.

Press the lever toward W to zoom out.

- The image will be more grainy the more you zoom to a subject because only Digital zoom is available during movie recording.
- When movie recording while zooming, images may become jittery.



Note:

- Unless OFF is selected in All Reset, the setting will be canceled when the power is turned off. (p. 188)

EXPOSURE COMPENSATION

In addition to automatic exposure, you can also adjust it manually by +/- 2 (approx. 1/3 steps). Adjust + to increase the exposure, and - to decrease the exposure. Confirm the settings by turning on the LCD monitor.

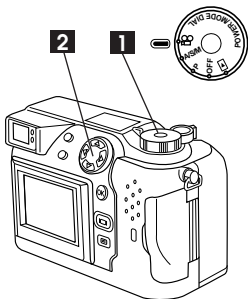

1 Set the Mode dial to .

- The exposure setting will be displayed.

2 Press the right arrow on the Jog dial for + adjustment and the left arrow for - adjustment.

-  appears on the control panel when a setting other than ± 0 is selected.

Exposure compensation

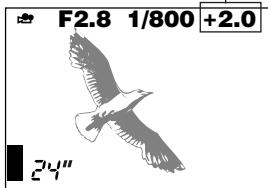

-2.0 ± 0 +2.0
↓ ↓ ↓



Note:

- Unless OFF is selected in All Reset, the setting will be canceled when the power is turned off. (p. 188)
- Although the brightness of the LCD monitor can be changed with the exposure compensation, it may not appear to change when the subject is mostly dark. In such a case, play the recorded movie on the LCD monitor to check its brightness.

MANUAL FOCUS

With Manual focus, you can select a pre-adjusted focal length.

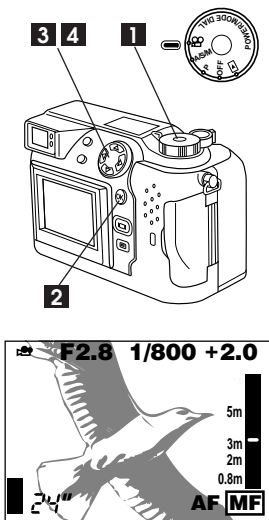

Control panel

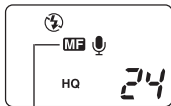

Manual focus

- 1** Set the Mode dial to .
- 2** Press the OK button to turn on the LCD monitor.
- 3** Press the right arrow on the Jog dial to select the Manual focus mode.
 - **MF** appears on the control panel.
 - To cancel, press the left arrow on the Jog dial. When **MF** disappears on the control panel, press the OK button.
- 4** While looking at the LCD monitor, press the top/bottom arrows on the Jog dial to select the distance.
 - The display will be enlarged to make focusing easy.

MANUAL FOCUS (Cont.)

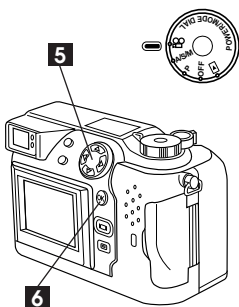

- 5** When the cursor is moved below 2.6ft, shorter distances will appear on the LCD monitor.

- 6** Press the OK button to save the setting. The setting appears on the LCD monitor in red letters.

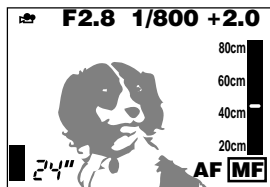



Note:

- You cannot perform Manual focus during movie recording.
- Unless OFF is selected in All Reset, the setting will be canceled and reset to auto focus when the power is turned off. (p. 188)
- The distances on the LCD monitor are for reference only.

MOVIE PICTURE RECORD MENU

* Press the Menu button to set the following items when the Mode dial is set to  . (p. 38)

Monitor Display	Use
 ↓	Using the Selftimer/remote control. (p. 132)
WB ↓	Selecting the white balance. (p. 136)
ISO ↓	Selecting the ISO sensitivity. (p. 138)
FUNCTION ↓	Using picture effects. (p. 140)
CARD SETUP ↓	Formatting the card. (p. 141)
MODE SETUP ↓	Making adjustments. [All reset (p. 188), Sharpness (p. 193), Beep sound (p. 198), Rec view (p. 201), Brightness (p. 209), Date/time set (p. 28), Meters/feet (p. 211), File number (p. 206)]
 ↙	Selecting the recording mode (SQ/HQ). (p. 143)

SELFTIMER/REMOTE CONTROL

Use a tripod to hold the camera securely.

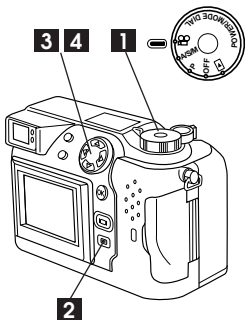

1 Set the Mode dial to .

2 Press the Menu button to display the Menu.

3 Press the top/bottom arrows on the Jog dial to select .

4 Press the right arrow on the Jog dial, then press the top/bottom arrows to select ON.

-  appears on the control panel.

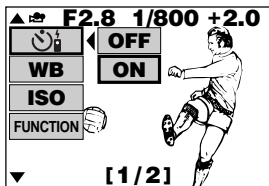

Control panel

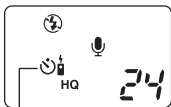

Selftimer/remote control

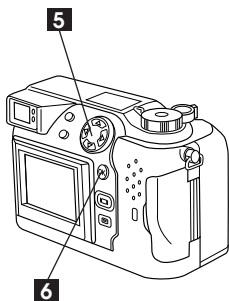

5 Press the left arrow on the Jog dial to confirm the setting.

6 Press the OK button to save the setting and cancel the Menu.

- Pictures can also be taken without pressing the OK button. (p. 134/135)

Note:

- Unless OFF is selected in All Reset, the setting will be canceled when the power is turned off. (p. 188)

SELFTIMER/REMOTE CONTROL (Cont.)

RECORDING A MOVIE USING THE SELFTIMER

Shutter release button

Selftimer/Remote control signal

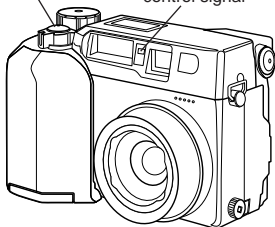

When the shutter is released, the Selftimer/Remote control signal lights for approx. 10 seconds then blinks for approx. 2 seconds before the movie is recorded.

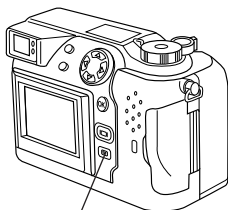

Menu button

To stop the activated selftimer, press the Menu button.

Note:

- The Selftimer/Remote control mode will be canceled after a movie is recorded using the Selftimer.

RECORDING A MOVIE USING THE REMOTE CONTROL

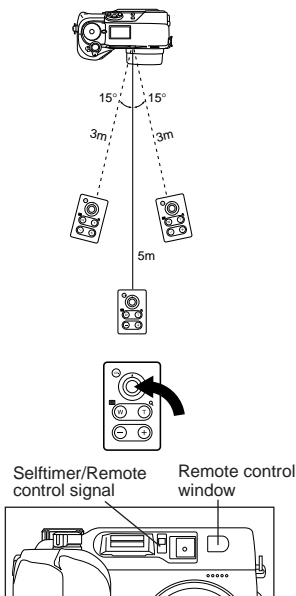

Compose the picture, aim the remote control at the Remote control window on the camera, then press the Shutter release button on the remote control to record a movie.

- The Selftimer/Remote control signal blinks for approx. 3 seconds before the movie is recorded. If the signal does not blink when the Shutter release button is pressed, move closer to the camera and press it again. The signal does not light when there is frequency interference. In such a case, change the frequency according to the remote control instructions.
- See page 118 for using the Remote control in the Display mode.

Note:

- The Selftimer/Remote control mode will remain after a movie is recorded using the Remote control.
- The working distance may be reduced in brightly lit areas, such as under direct sunlight.
- Do not subject the Remote control window to bright light.
- When the remote control is not operated for approx. 3 minutes, the Selftimer/Remote control mode will be canceled.

WHITE BALANCE



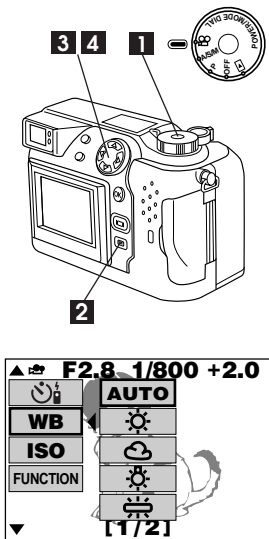

You can select the white balance according to the light source.



1 Set the Mode dial to .

2 Press the Menu button to display the Menu.

3 Press the top/bottom arrows on the Jog dial to select WB.

4 Press the right arrow on the Jog dial, then press the top/bottom arrows to select AUTO,  (Daylight),  (Overcast),  (Tungsten light) or  (Fluorescent).

- WB appears on the control panel when a setting other than AUTO is selected.

Control panel

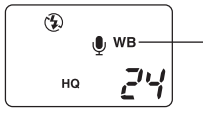

Manual white balance

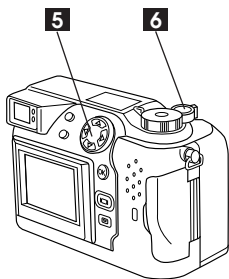

5 Press the left arrow on the Jog dial to confirm the setting.

6 If you record a movie without pressing the OK button, the setting will be valid until the Menu is canceled.

- Press the OK button to save the setting and cancel the Menu.

Note:

- Select AUTO in normal situations.
- The Manual white balance may not work under special lighting.
- Unless OFF is selected in All Reset, the setting will be canceled and reset to auto when the power is turned off. (p. 188)
- Confirm results in the Display mode.

ISO

You can select the sensitivity from AUTO, as well as approx. 100, 200 and 400.

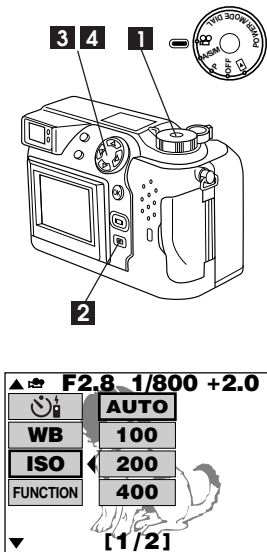

- 1** Set the Mode dial to .
- 2** Press the Menu button to display the Menu.
- 3** Press the top/bottom arrows on the Jog dial to select ISO.
- 4** Press the right arrow on the Jog dial, then press the top/bottom arrows to select the sensitivity.

- ISO appears on the control panel when a setting other than AUTO is selected.

Control panel

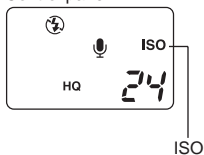

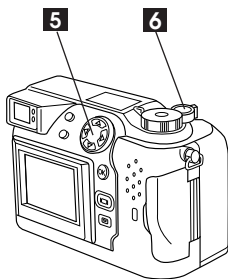

5 Press the left arrow on the Jog dial to confirm the setting.

6 If you record a movie without pressing the OK button, the setting will be valid until the Menu is canceled.

- Press the OK button to save the setting and cancel the Menu.

Note:

- Unless OFF is selected in All Reset, the setting will be canceled and reset to auto when the power is turned off. (p. 188)
- Images will appear grainy when the ISO is high.
- When AUTO is selected, the ISO is automatically set high in low-light situations when the flash is not used, to prevent blurring from camera movement.
- The sensitivity scale is based on the one used for picture film, but the numbers are for reference only.
- The higher the ISO, the faster the shutter speed that can be used and the lower the amount of light required.

PICTURE EFFECTS

You can select from two picture effects.

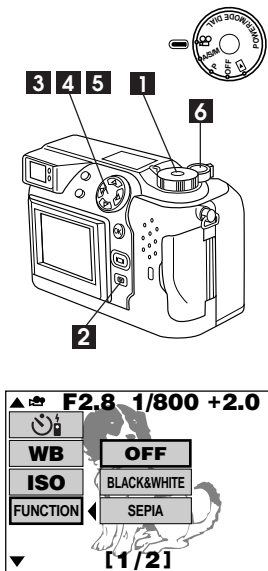

- 1** Set the Mode dial to .
- 2** Press the Menu button to display the Menu.
- 3** Press the top/bottom arrows on the Jog dial to select FUNCTION.
- 4** Press the right arrow on the Jog dial, then press the top/bottom arrows to select the desired picture effect.
- 5** Press the left arrow on the Jog dial to confirm the setting.
- 6** If you record a movie without pressing the OK button, the setting will be valid until the Menu is canceled.
 - Press the OK button to save the setting and cancel the Menu.

Note:

- Unless OFF is selected in All Reset, the setting will be canceled and reset to off when the power is turned off. (p. 188)

CARD SETUP (CARD FORMAT)

You can format the card.

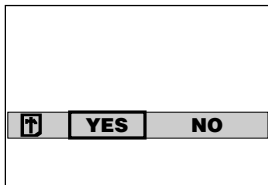
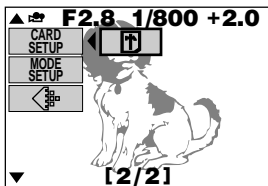
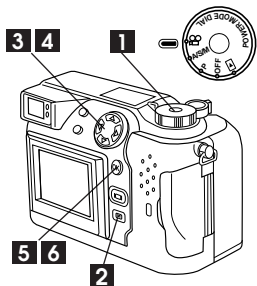

- 1 Set the Mode dial to .
- 2 Press the Menu button to display the Menu.
- 3 Press the top/bottom arrows on the Jog dial to select CARD SETUP.
- 4 Press the right arrow on the Jog dial to select .
- 5 Press the OK button to display YES NO.
- 6 Press the OK button again with YES selected to format the card.
 - To cancel, select NO using the right arrow on the Jog dial and press the OK button.

CARD SETUP (CARD FORMAT) (Cont.)

Note:

- Formatting the card erases the existing data, including pictures which have been write-protected from the camera. Be careful not to erase important data when formatting a recorded card.
- Formatting will not be engaged when a write-protect adhesive seal is placed on the card.
- Non-Olympus brand cards or cards formatted from or used in a computer must be formatted by the camera. These cards may take longer to record than recommended Olympus brand cards.
- It is highly recommended that you confirm the contents before formatting.

SELECTING THE RECORDING MODE

You can select the Standard Quality mode (SQ) or the High Quality mode (HQ).

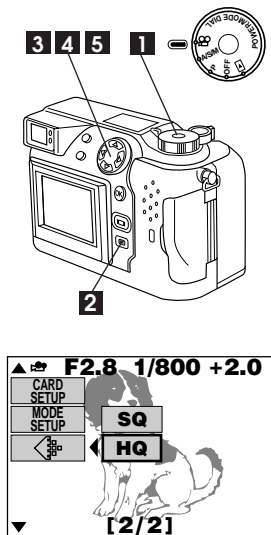

1 Set the Mode dial to .

2 Press the Menu button to display the Menu.

3 Press the top/bottom arrows on the Jog dial to select .

4 Press the right arrow on the Jog dial, then press the top/bottom arrows to select the recording mode.

- The selected recording mode appears on the control panel.

5 Press the left arrow on the Jog dial to confirm the setting.

Control panel

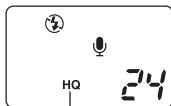

Recording mode

SELECTING THE RECORDING MODE (Cont.)

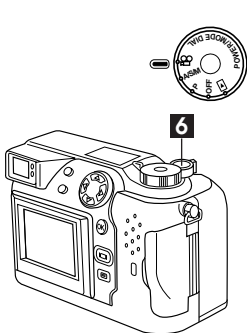

6 If you record a movie without pressing the OK button, the setting will be valid until the Menu is canceled.

- Press the OK button to save the setting and cancel the Menu.

Mode	Resolution
HQ	320 x 240 (12.5 frames/sec.)
SQ	160 x 120 (12.5 frames/sec.)

Seconds that Movies can be Photographed







Recording mode	Resolution	Memory capacity				
		2MB	4MB	8MB	16MB	Over 32MB
HQ	320 x 240 (12.5 frames/sec.)	6	13	27	55	75
SQ	160 x 120 (12.5 frames/sec.)	25	53	108	218	300

Note:

- The seconds remaining varies according to the recording mode.
- Unless OFF is selected in All Reset, the setting will change to HQ when the power is turned off. (p. 188)

MOVIE PICTURE DISPLAY MENU



* Press the Menu button to set the following items when the Mode dial is set to  and a movie picture is displayed on the LCD monitor. (p. 38)

Monitor Display	Use
  ↓	Displaying movie pictures as a movie. (p. 146)
 ↓	Displaying information about the image (date and time, file name, etc.). (p. 148)
 ↓	Creating a movie index (p. 150) and editing movies. (p. 152)
 ↓	Performing All-Frame erase (p. 154) or Card format. (p. 156)
 ↓	Making adjustments. [All reset (p. 188), Beep sound (p. 198), Index-Display adjustment (p. 212), Brightness (p. 209), Date/time set (p. 28)]

PLAYING MOVIES

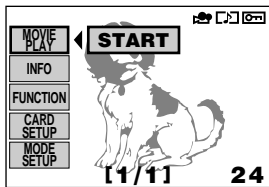
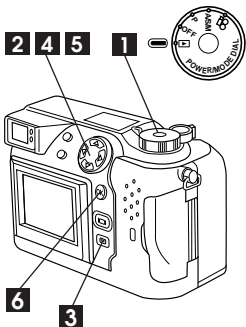
You can play movies you have recorded.  will appear on the LCD monitor for movies.



- 1** Set the Mode dial to  .
 - The LCD monitor turns on automatically.
- 2** Display a picture with  on the LCD monitor using the Jog dial.
 - Picture information is displayed for 5 seconds. Press the Erase or Menu button to display the picture information again.
- 3** Press the Menu button to display the Menu.
- 4** Press the top/bottom arrows on the Jog dial to select MOVIE PLAY.
 - To cancel, press the Menu button.
- 5** Press the right arrow on the Jog dial to select START.
- 6** Press the OK button to start the movie.
 - The card access lamp blinks for a moment, then the movie starts.

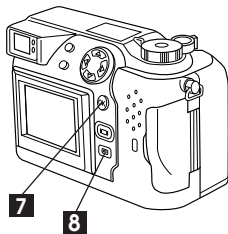

7 Press the OK button during the movie to pause it. Press it again to restart.

- The following operations can be performed during pause.

Press the top arrow on the Jog dial to pause at the beginning of the movie. Press the bottom arrow to pause at the ending of the movie.

Press the right arrow on the Jog dial to start the movie. Press the left arrow to play it backwards.

8 Press the Menu button when movie playback is finished. The Menu reappears. Press it again to exit the Menu.

Note:

- Sound cannot be played back by this camera. Connect it to a TV or personal computer for sound playback.(p. 118)

PICTURE INFORMATION

You can display picture information (settings, date/time, file number, etc.) on the LCD monitor.

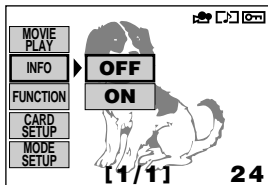
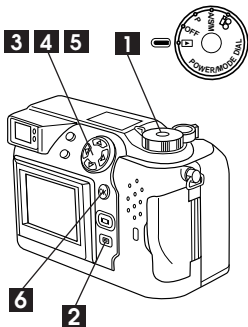

- 1 Set the Mode dial to .
- 2 Press the Menu button to display the Menu.
- 3 Press the top/bottom arrows to select INFO.
 - To cancel, press the Menu button.
- 4 Press the right arrow on the Jog dial, then press the top/bottom arrows to select ON.
- 5 Press the left arrow on the Jog dial to confirm the setting.
- 6 Press the OK button to save the setting and cancel the Menu.

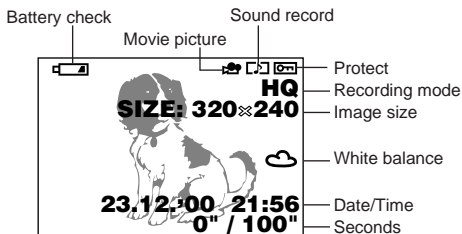

During movie recording

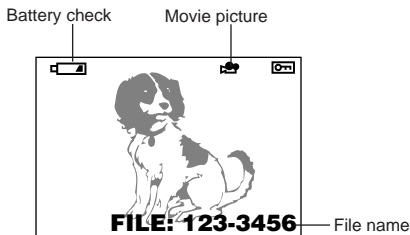

When a movie picture is selected

Note:

- When picture information is displayed, the frame number will not be displayed.
- Unless OFF is selected in All Reset, the setting will be canceled when the power is turned off. (p. 188)
- The information is displayed for a period of 5 seconds.

FUNCTIONS

These functions enable you to create an index of recorded images and to edit images.

CREATING AN INDEX

Recorded movies can be displayed as an index. After an index is created, it can be saved on the card as a still picture image.

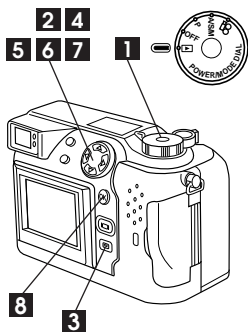

- 1 Set the Mode dial to .
- 2 Using the Jog dial, display an image with the mark on the LCD monitor.
- 3 Press the Menu button to display the Menu.
- 4 Press the top/bottom arrows on the Jog dial to select FUNCTION.
- 5 After pressing the right arrow on the Jog dial, press the top/bottom arrows to select MOVIE INDEX, then press the OK button.
- 6 Press the right/left arrows on the Jog dial to select the first frame for the index display, then press the OK button.
 - If the top arrow on the Jog dial is pressed, the first frame is displayed, and if the bottom arrow is pressed, the last frame is displayed. When the first frame is selected, the displayed images other than the last frame will change accordingly.

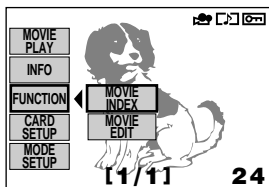

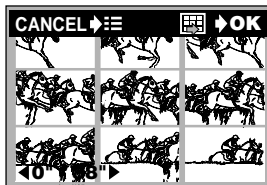
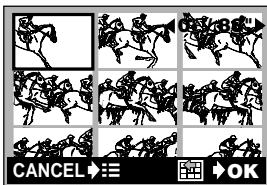

- The total movie time and time of the current frame will appear in the left corner on the LCD monitor.
- To go to the next frame, press the right arrow on the jog dial and to go the previous frame, press the left arrow.

7 Press the right/left arrows on the Jog dial to select the last frame for the index display.

- Just as when the first frame is selected, the image can be selected by using the Jog dial. When the last frame is selected, the displayed images other than the top frame will change accordingly.
- Press the Menu button to go to back to first frame selection.

8 Press the OK button to record the index image in the card and cancel the Menu.

- The index image will be recorded in the corresponding mode listed below.
 HQ → SQ2 (1024 x 768/HIGH)
 SQ → SQ2 (640 x 480/HIGH)

Note:



- The index can be displayed in 9 frames only.

FUNCTIONS (Cont.)

EDITING A MOVIE

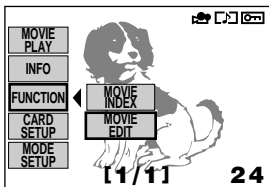
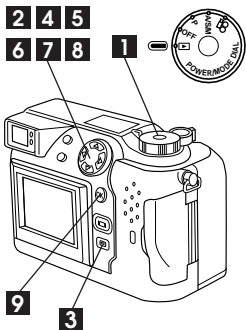
This function is used to delete unnecessary portions of recorded movies or to split one movie into two.



- 1 Set the Mode dial to .
- 2 Using the Jog dial, display an image with the  mark on the LCD monitor.
- 3 Press the Menu button to display the Menu.
- 4 Press the top/bottom arrows on the Jog dial to select FUNCTION.
- 5 After pressing the right arrow on the Jog dial, press the top/bottom arrows to select MOVIE EDIT, then press the OK button.



- 6** Press the right/left arrows on the Jog dial to select the first frame, then press the OK button.

- If the top arrow on the Jog dial is pressed, the first frame of the movie is displayed, and if the bottom arrow is pressed, the last frame is displayed.



- 7** Press the right/left arrows on the Jog dial to select the last frame, then press the OK button.

- Just as when selecting the top frame, the top/bottom arrows on the Jog dial can be used to select the frame.

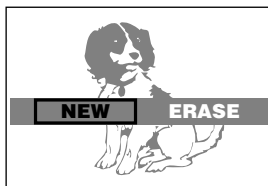

- 8** Press the right/left arrows on the Jog dial to select NEW or ERASE.

- If NEW is selected, the edited movie is saved as a new movie with a different name.
- If ERASE is selected, the edited movie is saved under the original name. The original movie is discarded.

- 9** Press the OK button to record the movie and cancel the Menu.

CARD SETUP

ALL-FRAME ERASE

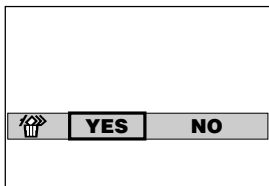
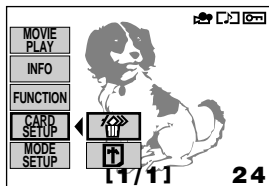
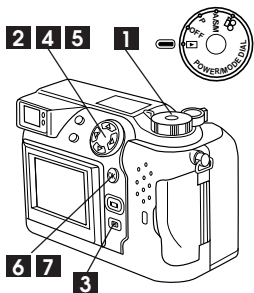

- 1 Set the Mode dial to .
- 2 Display a picture with on the LCD monitor using the Jog dial.
- 3 Press the Menu button to display the Menu.
- 4 Press the top/bottom arrows on the Jog dial to select CARD SETUP.
- 5 Press the right arrow on the Jog dial, then press the top/bottom arrows to select .
- 6 Press the OK button to display YES NO .

7 Press the OK button with YES selected to erase all the pictures in the card.

- To cancel, select NO using the right arrow on the jog dial.

8 When complete, NO PICTURE appears on the LCD monitor.

- Protected frames will remain in the card, and the last frame will be displayed. (p. 106)



Caution:

- Be careful not to erase important picture data by mistake as it cannot be retrieved.
- Never open the card cover, eject the card, remove the batteries, or pull the plug while erasing pictures. It may destroy the data in the card.
- When a write-protect adhesive seal is placed on the card, the camera does not enter the Erase mode.



Note:

- Formatting the card erases the existing data, including pictures which have been write-protected from the camera. Be careful not to erase important data when formatting a recorded card.
 - Formatting will not be engaged when a write-protect adhesive seal is placed on the card.
 - Non-Olympus brand cards or cards formatted from or used in a computer must be formatted by the camera. These cards may take longer to record than recommended Olympus brand cards.
 - It is highly recommended that you confirm the contents before formatting.
- 



4

STORING DATA FOR PRINTING PICTURES

- Recorded images can be printed out with a printer.
- Selected images can be reserved in a SmartMedia card for printing on a printer or at a photo lab that supports the DPOF (Digital Print Order Format) system.

ABOUT PRINT SETTINGS



You can make prints of images stored in a SmartMedia, using one of the following methods:

1. Images in the SmartMedia can be selected for printing, as well as the number of copies for each and whether or not to print the date and time with them. This information is saved in the card (Print-reserve) for later printing from a printer or at a photo lab that supports DPOF.
2. If a SmartMedia with Print-reserve data recorded in it is inserted into an Olympus CAMEDIA P-330NE/P-300E printer, printing can be performed at the touch of a button. For more information, consult your printer's user manual.
3. Images can be transferred directly to a personal computer via USB or a PC connection kit, or by using an optional FlashPath, PC Card Adapter or USB SmartMedia Reader/Writer. Images can then be printed on a printer connected to the personal computer using a software application. For more information, consult the software's user manual.

About DPOF

DPOF (Digital Print Order Format) is a system that allows you to select images in a SmartMedia card to be printed as well as the number of copies to make of each. This information is stored in the card for use by printers or photo labs that support this system to make prints automatically.

Note:

- Images taken with this camera can also be printed using a printer or at a photo lab that supports the Design rule for Camera File system/DCF.
- DPOF reservations set by another device cannot be changed by this camera. Make changes using the original device.
- If a card contains DPOF reservations set by another device, entering reservations using this camera may overwrite the previous reservations.
- Even if an image appears with the message "PICTURE ERROR", print reserve may be performed on it. In such a case, the print reserve icon () does not appear on the screen where an image is displayed for full view. Since  appears on the screen where multiple images are displayed (index-display mode), it is possible to confirm the print reserve status.
- This camera cannot be directly connected to printers such as the Olympus P-300E digital printer.
- Not all functions may be available on all printers or at all photo labs.

PRINT-RESERVE

You can store data for making prints with a printer or at a lab that supports this system.

ALL-FRAME PRINT RESERVE

You can store data for printing all the pictures in the card as well as choose the number of prints to make.

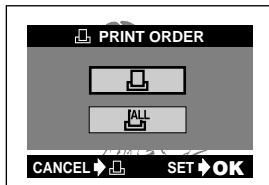
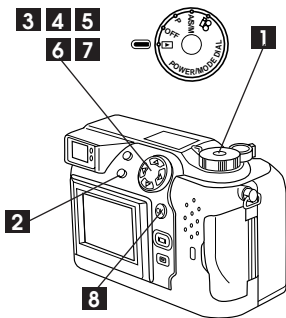

- 1 Set the Mode dial to .
- 2 Press the Print button to display the Print reserve setting screen.
 - If Print-reserve data is already stored in the card, a screen will appear giving you the choice of resetting the data or keeping it. (p. 171)
- 3 Select using the Jog dial, then press the OK button.
 - The print number and date setting screen is displayed.
- 4 Press the top/bottom arrows on the Jog dial to select x .

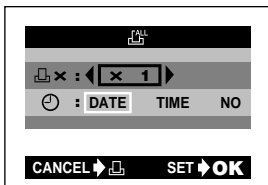

5 Press the left/right arrows on the Jog dial to enter the number.

- Press the left arrow to decrease the number, and the right arrow to increase it.
- The number of prints can be set from 0 to 10.

6 Press the top/bottom arrows on the Jog dial to select .

7 Press the left/right arrows on the Jog dial to select DATE, TIME or NO.

8 Press the OK button.

- The Menu screen disappears and the print reserve indicator and the number of prints are displayed on the screen.

Note:

- The setting will remain until it is readjusted.
- If you are printing using the P-330NE or P-330E, only the first 255 images can be printed.
- Print reserve may take considerable time in some cases.

PRINT-RESERVE (Cont.)

SINGLE-FRAME PRINT RESERVE

You can store data for making prints with a printer or at a lab that supports this system.

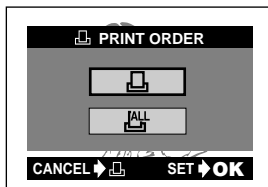
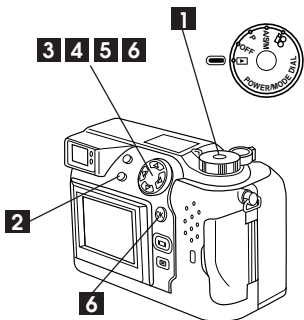

.....
1 Set the Mode dial to  and display a still picture.

2 Press the Print button to display the Print reserve setting screen.

- If Print-reserve data is already stored in the card, a screen will appear giving you the choice of resetting the data or keeping it. (p. 171)

3 Press the top/bottom arrows on the Jog dial to select , then press the OK button.

- The Print reserve setting screen is displayed. If the zoom lever is pressed toward T, printing with trimming is available. (p. 168)

Print reserve selection screen

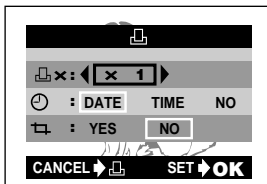
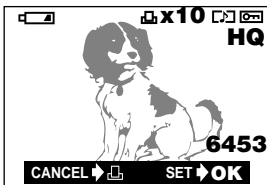

4 Press the arrows on the Jog dial to select the image you would like to print.

- Left arrow: Displays the image in the previous frame.

- Right arrow: Displays the image in the next frame.

- Top arrow: Displays the image 10 frames back.

- Bottom arrow: Displays the image 10 frames forward.

- Press the Zoom lever toward W to display an index of images.

- Left arrow: Moves to the previous frame.

- Right arrow: Moves to the next frame.

- Top arrow: Displays the previous page.

- Bottom arrow: Displays the next page.

The index is displayed as follows: when the number of frames shown in the Index-Display mode (p. 205) is 4, 9 or 16 frames, then 2, 6 or 12 frames are displayed respectively.

5 Press the OK button to display the setting menu.

6 Press the top/bottom arrows on the Jog dial to select $\downarrow x$.

PRINT-RESERVE (Cont.)

7 8 9 10 11

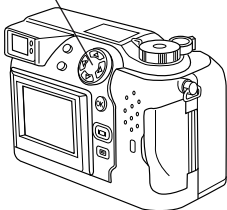

- 7** Press the left/right arrows on the Jog dial to enter the number of prints.

- Press the left arrow to decrease the number, and the right arrow to increase it.
- The number of prints can be set from 0 to 10.
- If the number of prints has already been set for the selected image, the previously set number is displayed.

- 8** Press the top/bottom arrows on the Jog dial to select \odot .

- 9** Press the left/right arrows on the Jog dial to select DATE, TIME or NO.

- 10** Press the top/bottom arrows on the Jog dial to select \square .

- 11** Press the left/right arrows on the Jog dial to select YES or NO.

- If trimming is not set, YES cannot be selected.
- Refer to “Trimming Print Reserve” for setting trimming. (p. 168)

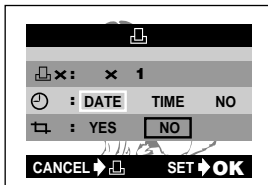
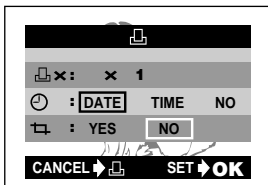

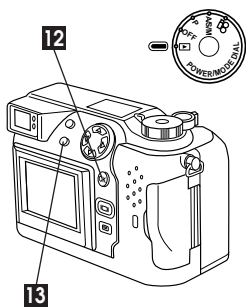

12 Press the OK button.

- The Menu screen disappears and the print reserve indicator and the number of prints are displayed on the screen.
- To set print reserve for more images, repeat steps 4 through 12.

13 Press the Print button to exit the Print reserve mode and return to the Display mode.

Note:

- Images taken with this camera can be printed using a printer or at a lab that supports the Design rule for Camera File system/DCF.
- If you are printing using the P-330NE or P-330E, only the first 255 images can be printed.
- Print reserve may take considerable time in some cases.

PRINT-RESERVE (Cont.)

TRIMMING PRINT RESERVE

You can print an enlarged part of a recorded picture.

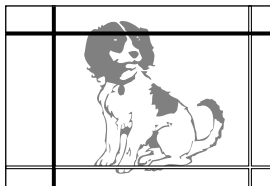
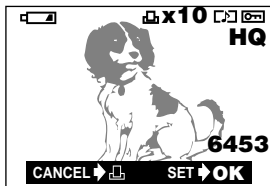
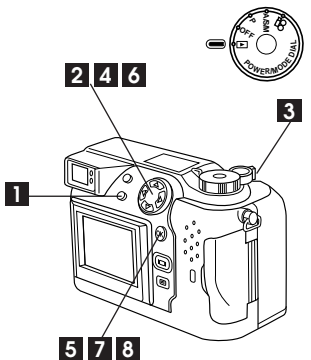

Trimming mode display

.....

1 Select PRINT ORDER— , then press the OK button. The Print reserve selection screen appears. (p. 164)

2 Press the arrows on the Jog dial to display the image you want to print.

- Left arrow: Displays the image in the previous frame.
- Right arrow: Displays the image in the next frame.
- Top arrow: Displays the image 10 frames back.
- Bottom arrow: Displays the image 10 frames forward.

3 Press the zoom lever toward T to display the Trimming mode screen.

- The selected item is displayed in green.

4 Move the cursor to set the top left corner of the image you would like to print.

- Move the cursor up and down by pressing the top/bottom arrows on the Jog dial, and move it left and right by pressing the left/right arrows.
- Press the zoom lever toward W to move the cursor to the top left edge of the image, and press it toward T to move it to the bottom right edge.

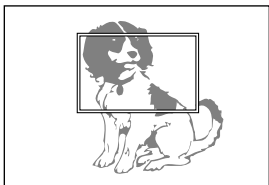
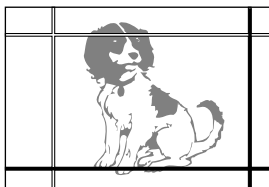

Displayed for 1 second.



When the setting is finished, the image and frame are displayed for 1 second, then the PRINT ORDER menu reappears.

5 When the position is set, press the OK button.

6 Move the cursor to set the bottom right corner of the image that you would like to print.

- Use the same procedure as in step 4.
- Press the Print button to go back to the upper left corner setting screen.

7 Press the OK button to set the trimming size. The image is displayed on the LCD monitor.

8 Press the OK button again to display the Single-frame print reserve screen.

- Following the procedure for Single-frame print reserve, set the number of prints, date/time, and trimming. (p. 164)
- If you would like to continue to trim other images, repeat the above procedure from steps 1 to 8.

PRINT-RESERVE (Cont.)

Note:

- The size of the printed image will vary depending on the print reserve settings. An image trimmed to a small size will have lower resolution.
- For best results with close-up prints, it is recommended to use the TIFF, SHQ or HQ mode.
- The vertical to horizontal ratio in the trimming screen can be changed using the Jog dial, but if the zoom lever is used, the ratio is fixed at 4:3.

RESETTING PRINT RESERVE

This resets all the print reserve settings for images saved in a card.

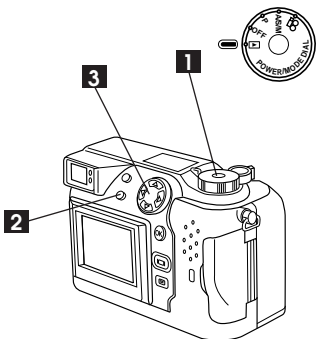

.....

1 Set the Mode dial to  and display a still picture.

2 Press the Print button to display the Print order setting screen.

- If there are no images in the card, this screen is not displayed.

3 Press the left/right arrows on the Jog dial to select RESET, then press the OK button.

- To keep the print order, select KEEP and press the OK button.
- To remove the selected image only, set the number of prints in Single-frame print reserve to 0.

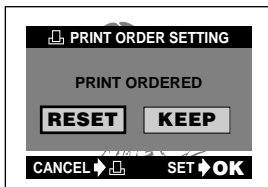

Note:

- If RESET is selected, the print reserve will be canceled for all the images in the card.



5

USING A PERSONAL COMPUTER

COMPUTER SYSTEM REQUIREMENTS

When using the provided utility software:

Personal computers used with this camera must conform to the following minimum standards.

To connect this camera directly to a personal computer, it must have either a serial port or USB port.

- Windows

CPU: Pentium or later

OS: Windows 98/98 Second Edition/2000 Professional (USB)

Windows 95/98/98 Second Edition/2000 Professional/NT 4.0 SP3
or later

Available HD space: 100MB or more

RAM: 32MB or more (64MB or more recommended)

Connectors: USB port (USB connection)

RS-232C port (serial connection)

D-SUB 9-pin connector (serial connection)

Monitor: More than 32000 colors

Minimum monitor resolution: 800 x 600 pixels

QuickTime 4.0 must be installed to play back movies.

Note:

- USB support is not available under the following environments, even for PCs equipped with a USB port.
 - Windows 98 upgrade (from Windows 95)
 - Windows 95
 - Windows NT 4.0
- To record or play back sound, a sound card and a microphone are required.

- Apple Macintosh
CPU: PowerPC
OS: Mac OS 8.6 to 9 (USB)
Mac OS 7.6.1 to 9 (serial)
Available HD space: 100MB or more
RAM: 32MB or more (8MB or more free memory for the included application)
Connectors: USB port
Serial port
Monitor: More than 32000 colors
Minimum monitor resolution: 800 x 600 pixels
QuickTime 4.0 must be installed to play back movies.

Note:

- For USB connection, your Macintosh must have a USB port.
- To record sound, microphone is required.

INSTALLING PROVIDED SOFTWARE

To take full advantage of a wide range of functions, including download, display, storage and panorama, your Olympus digital camera comes with software applications and CAMEDIA Master. For installation and operation, please refer to the software's online documentation.

QuickTime 4.0 must be installed on the computer to play back movies.

CONNECTING TO A PERSONAL COMPUTER

Use the appropriate connector according to your computer's specifications.

- **For USB-equipped computers (IBM PC/AT compatible, Apple Macintosh)**

Connect the provided USB cable to the USB port on your computer.

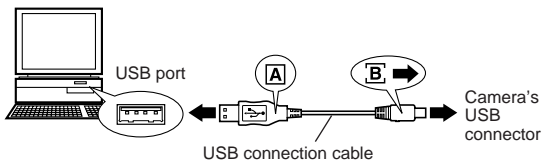

- **For serial port-equipped computers (IBM PC/AT compatible)**

Connect the provided RS-232C PC serial cable to the serial port (COM1, COM2, etc.) on your computer.

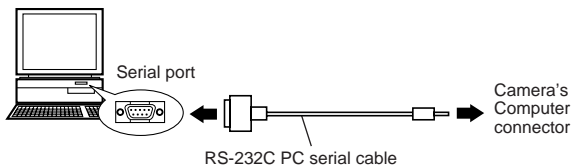

- If your Macintosh does not have a built-in USB port, use the optional conversion connector for Macintosh.

Note:

- In order to prevent battery consumption, use of the optional AC adapter is recommended.

USING A PERSONAL COMPUTER

- 1** Make sure that the power of the personal computer and the camera are OFF.
- 2** Connect the provided USB cable or RS-232C PC serial cable to your computer. (See the previous page for details)
- 3** Remove the lens cap, and connect the cable to the camera's USB connector or computer connector, then turn on your computer.

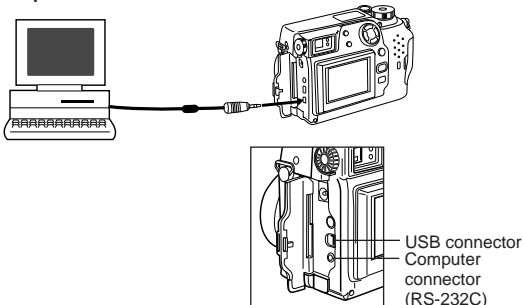

- 4** Set the Mode dial on the camera to .
- 5** Start CAMELIA Master on the computer.

Note:

- If you are using a USB cable to make connections, make sure that your personal computer support it. Contact your personal computer maker concerning your personal computer's environment.
- Communications with a personal computer cannot be accomplished with a USB cable alone. Be sure to download images using CAMELIA Master.
- If a USB connection is used, make sure that USB is operating normally on the personal computer. For more information, consult your personal computer's operation manual.

TRANSFERRING DATA FROM SmartMedia

PC CARD ADAPTER

The picture data in the SmartMedia can be directly transferred to a personal computer equipped with a PC card (PCMCIA) slot or an external PC card reader/writer, using the optional PC Card Adapter.

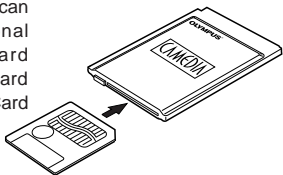

FlashPath FLOPPYDISK ADAPTER

The picture data in the SmartMedia can be directly transferred to a personal computer equipped with a 3.5" FDD, using the optional FlashPath Floppydisk Adapter.

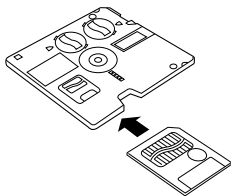

SmartMedia READER/WRITER

The picture data in the SmartMedia can be directly transferred to a personal computer (Windows 98/Mac OS 8.6) equipped with a USB port, using the optional SmartMedia Reader/Writer.

Note:

- Check for compatibility. This equipment may not function properly on all operating systems.
- Do not use a SmartMedia with a write-protect adhesive seal on a computer as it will cause errors. (Refer to the instructions of the adapters.)

USING CAMEDIA Master

VIEWING IMAGES STORED IN THE CARD ON YOUR COMPUTER

You can view images stored in a SmartMedia card via CAMEDIA Master.



- 1** Start CAMEDIA Master on the computer.

- 2** Click on [My Camera].

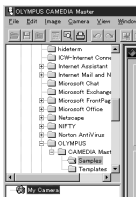

- 3** A thumbnail index of stored images will be displayed.



USING CAMEDIA Master (Cont.)



- 4** Place the cursor on the desired image and double-click on it.
 - This will open the selected image.

TRANSFERRING DATA USING CAMEDIA Master

CAMEDIA Master transfers images stored in the card to your computer.

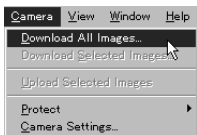

-
- 1** Start CAMEDIA Master on the computer.

- 2** Select [Camera] – [Download All Images] on the menu bar.
 - The computer will start transferring images from the camera to the computer.

Note

- You can view images using software such as graphics applications that support JPEG like Paint Shop Pro/Photoshop, Internet browsers like Netscape Communicator/Microsoft Internet Explorer, and CAMEDIA Master (supplied with the camera).

PROCESSING IMAGES USING CAMEDIA Master

You can process images (changing tones, composing, and so on) using the provided CAMEDIA Master or other application software.

MAKING DARK IMAGES BRIGHT

Some images may come out darker than expected. You can try taking pictures again right after shooting, but may often miss the right moment for a good picture. This is where CAMEDIA Master Instant Fix comes in. You can easily brighten images.



.....

1 Place the cursor on the desired image and double-click on it.

- This will display the selected image.

PROCESSING IMAGES USING CAMEDIA Master (Cont.)

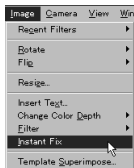

2 Select [Image] – [Instant Fix] on the menu bar.

- This will brighten the selected image.



CORRECTING BLURRY IMAGES

Backlight sometimes makes the whole image blurry, and an object which stands before the subject may be out-of-focus. Use CAMEDIA Master Sharpen when this happens to sharpen the whole image. However, you should note that it doesn't eliminate image blur completely.



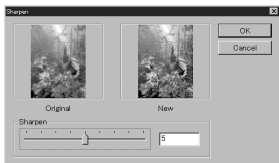
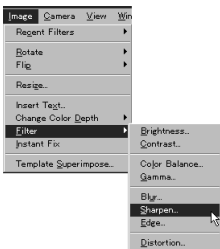

1 Place the cursor on the image you want to correct and double-click on it.

- This will display the selected image.

2 Select [Image] – [Filter] – [Sharpen] on the menu bar.

3 Specify the degree of sharpness either by sliding the slide bar or inputting a value from 1 to 9, while comparing “Original” and “New”.

4 When the desired result is obtained, click on [OK].

PROCESSING IMAGES USING CAMEDIA Master (Cont.)



- This will sharpen the selected image.

COMPOSING IMAGES WITH TEMPLATES

You can easily compose images with templates in CAMEDIA Master.



+



=

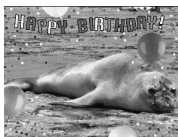

-
- 1 Place the cursor on the image you want to compose and double-click on it.
- This will display the selected image.

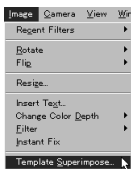

2 Select [Image] – [Template Superimpose] on the menu bar.

- This will display the compose window.



3 Select a template and click on [Apply].

- This will display the preview image.



4 When you are happy with the sample image, click on [OK].

- The composed image will be displayed.

There are a lot of functions for editing images in additions to those mentioned here. See CAMEIA Master user's manual located in the CAMEIA Master folder for information on all available functions.



6

CAMERA SETTINGS

- The settings can be adjusted in the Menu. Each Menu (still picture record menu, still picture display menu, movie picture record menu and movie picture display menu) has different available settings. (p. 67/108/131/145)

ALL RESET

Clears adjustments and returns to the default settings.

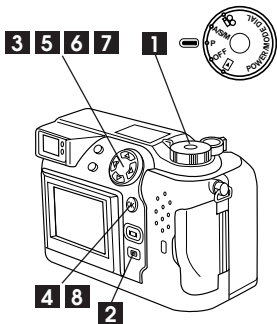

.....

1 Set the Mode dial to P, A/S/M or .

2 Press the Menu button to display the Menu.

3 Press the top/bottom arrows on the Jog dial to select **MODE SETUP**, then press the right arrow to select **SETUP**.

4 Press the OK button to display the Mode setting screen.

5 Press the top/bottom arrows on the Jog dial to select **ALL RESET**.

6 Press the right arrow on the Jog dial, then press the top/bottom arrows to select **ON** or **OFF**.

- When **ON** is selected, settings will be canceled and reset to the default when the power is turned off.

- When **OFF** is selected, settings will remain even when the power is turned off.

7 Press the left arrow on the Jog dial to confirm the setting.

8 Press the OK button to save the setting. Press again to cancel the Menu.

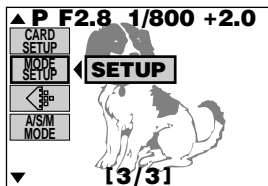

(Still picture record menu)

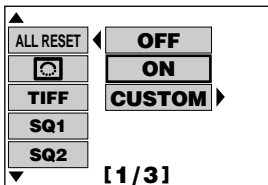

With ON selected, the settings of the following items will be canceled and reset to the default when the power is turned off.

Aperture priority mode (p. 52),
Shutter priority mode (p. 53),
Manual mode (p. 55),
Zoom (p. 56/127),
Exposure compensation (p. 57/128),
Flash modes (p. 58),
Spot metering mode (p. 62),
Macro mode (p. 63),
Macro + Spot metering mode (p. 64),
Manual focus (p. 65/129),
Sequence mode (p. 68),
Selftimer/Remote control (p. 70/132),
Auto bracket (p. 74),
White balance (p. 76/136),
ISO setting (p. 78/138),
Flash correction (p. 80),
Slow shutter synchronization flash (p. 82),
Flash select (p. 86),
Digital zoom mode (p. 90),
Picture effects (p. 92/140),
Sound record (p. 93)
Recording mode (p. 99/143),
A/S/M mode setting (p. 101),
Picture information (p. 110/148),

Note:

- The setting will remain until it is readjusted.

CUSTOM SETTINGS

When the power is turned off, the camera can revert to the settings that you desire. Even if the settings are changed while taking pictures, the camera will return to the selected state when the power is turned on again.

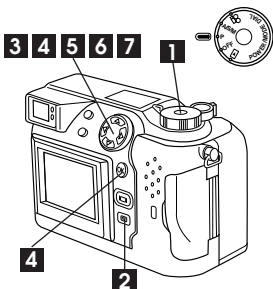

1 Set the Mode dial to P, A/S/M or .

2 Press the Menu button to display the Menu.

3 Press the top/bottom arrows on the Jog dial to select MODE SETUP, then press the right arrow to select SETUP.

4 Press the OK button to display the Mode setting screen.

5 Press the top/bottom arrows on the Jog dial to select ALL RESET.

6 Press the right arrow on the Jog dial, then press the top/bottom arrows to select CUSTOM.

7 Press the right arrow on the Jog dial to enter custom settings.

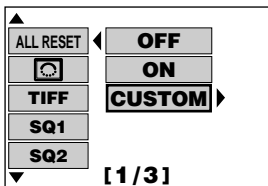
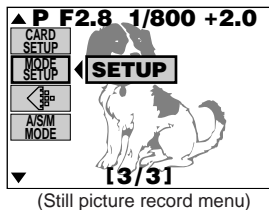

8 9 10 12

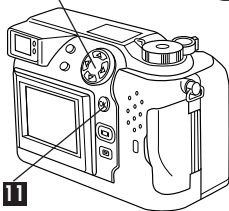

▲	FLASH MODE	▶	AUTO
	/	▶	OFF
	ZOOM	▶	32mm
	FNo	▶	F2.8
▼	SHUTTER	▶	1/800 [1/5]

8 Press the top/bottom arrows on the Jog dial to select the mode you would like to set. The modes that can be selected are shown in the table on the following page.

9 Press the right arrow on the Jog dial, then press the top/bottom arrows to select the desired value.

10 Press the left arrow on the Jog dial to confirm the setting.
• To enter more settings, repeat steps 7, 8 and 9.

11 Press the OK button to exit from the Custom settings screen and return to the MODE SETUP screen.

12 Confirm that CUSTOM is selected, then press the OK button to cancel MODE SETUP. Press it again to cancel the Menu. Even if the current settings are different from the custom settings, the custom settings will be saved in memory.

Note:

- The setting will remain until it is readjusted.

CUSTOM SETTINGS (Cont.)

Items which can be set to the desired state in CUSTOM.

Flash	Auto/Red-Eye Reducing/Fill-In/Off
Spot/Macro	Off/Spot/Macro/Spot + macro
Zoom position	32mm/50mm/70mm/96mm
Aperture value	F2.8 ~ F11
Shutter speed	1/800 ~ 16
Exposure compensation	1/3 EV increments up to ± 2 EV.
MF	AF/MF
Monitor (P)	Off/On
Drive	Single photo/Continuous photo/AF continuous photo/ Selftimer/Remote control/Auto bracket
Flash exposure compensation	1/3 EV increments up to ± 2 EV
Slow shutter synchronizing flash	Off/Before shutter/After shutter
Flash select	Main + extension/Extension
Digital zoom	Off/On
White balance	Auto/Daylight/Overcast/Tungsten light/Fluorescent
ISO	Auto/100/200/400
Function photography	Off/Black and white/Sepia/White board/Black board
Sound record	Off/On
Still photo quality mode	TIFF/SHQ/HQ/SQ1/SQ2
Manual mode	A/S/M
Movie image mode	HQ/SQ
Screen information display	Off/On

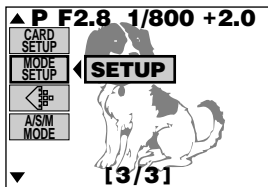
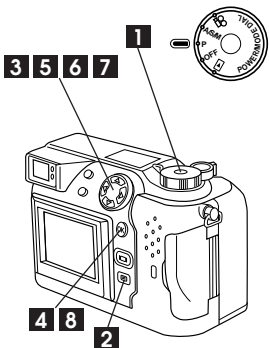

SHARPNESS

You can select the image sharpness.

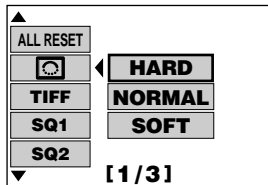

(Still picture record menu)



- 1 Set the Mode dial to P, A/S/M or .
- 2 Press the Menu button to display the Menu.
- 3 Press the top/bottom arrows on the Jog dial to select MODE SETUP, then press the right arrow to select SETUP.
- 4 Press the OK button to display the Mode setting screen.
- 5 Press the top/bottom arrows on the Jog dial to select .
- 6 Press the right arrow on the Jog dial, then press the top/bottom arrows to select NORMAL, SOFT or HARD.
- 7 Press the left arrow on the Jog dial to confirm the setting.
- 8 Press the OK button to save the setting. Press again to cancel the Menu.

Note:

- The setting will remain until it is readjusted.

TIFF SETTINGS

This sets the resolution for the TIFF mode.

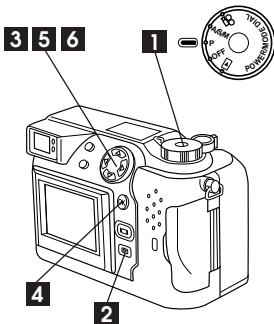

.....

1 Set the Mode dial to P or A/S/M.

2 Press the Menu button to display the Menu.

3 Press the top/bottom arrows on the Jog dial to select MODE SETUP, then press the right arrow to select SETUP.

4 Press the OK button to display the Mode setting screen.

5 Press the top/bottom arrows on the Jog dial to select TIFF.

6 Press the right arrow on the Jog dial to select SETUP and press OK button.

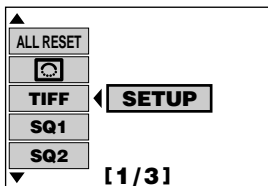
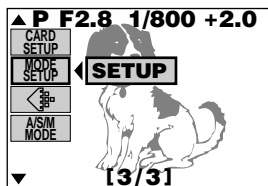

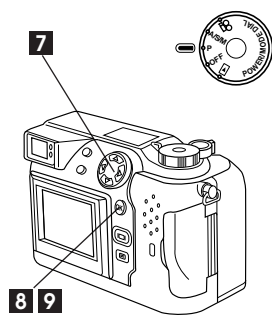

7 Use the top/bottom arrows on the Jog dial to select the resolution.

- 2048 x 1536, 1600 x 1200, 1280 x 960, 1024 x 768 or 640 x 480 are available.
- The compression rate for all resolutions is uncompressed TIFF.

8 Press the OK button to return to the Mode setting screen.

- Confirm the setting using the image in the LCD monitor.

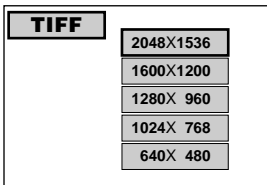

9 Press the OK button to save the setting. Press again to cancel the Menu.

Note:

- The setting will remain until it is readjusted.
- The greater the number of pixels, the longer the playback time, and the smaller the number of frames that can be photographed, so exercise caution. (p. 36/37)

SQ1, SQ2 SETTINGS

You can select the resolution and compression rate for SQ1 and SQ2. NORMAL quality allows more pictures to be stored in a card, while HIGH quality uses less compression, resulting in fewer visible artifacts in the JPEG image.

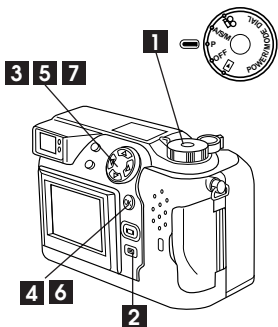

1 Set the Mode dial to P or A/S/M.

2 Press the Menu button to display the Menu.

3 Press the top/bottom arrows on the Jog dial to select MODE SETUP, then press the right arrow to select SETUP.

4 Press the OK button to display the Mode setting screen.

5 Press the top/bottom arrows on the Jog dial to select SQ1 or SQ2, then press right arrow on the Jog dial to select SETUP.

6 Press the OK button to display the Resolution setting screen.

7 Press the top/bottom arrows on the Jog dial to select the resolution.

- The resolutions that can be selected are shown in the following table.

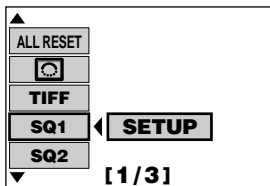
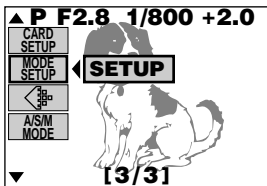

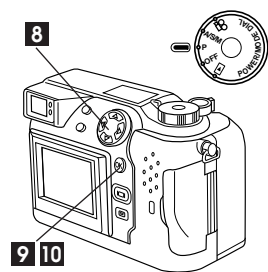

8 Press the right arrow on the Jog dial, then press the top/bottom arrows to select HIGH or NORMAL.

9 Press the OK button to return to the MODE SETUP screen.

- Confirm the setting using the image in the LCD monitor.

10 Press the OK button to save the setting. Press again to cancel the Menu.

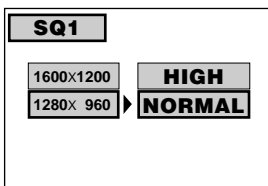

Recording mode

Image quality		Recording size	File format
SQ1	HIGH (High quality)	1600 x 1200	JPEG
	NORMAL		
	HIGH (High quality)	1280 x 960	
	NORMAL		
SQ2	HIGH (High quality)	1024 x 768	
	NORMAL		
	HIGH (High quality)	640 x 480	
	NORMAL		

Note:

- The setting will remain until it is readjusted.
- The greater the number of pixels, the longer the playback time, and the smaller the number of frames that can be photographed, so exercise caution. (p. 36/37)

BEEP SOUND

You can select the volume of the operating beep sound.

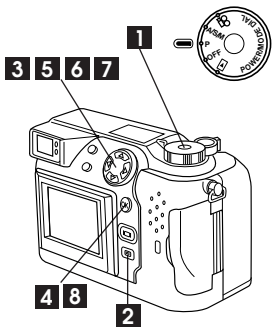

.....

1 Set the Mode dial to P, A/S/M, or .

2 Press the Menu button to display the Menu.

3 Press the top/bottom arrows on the Jog dial to select MODE SETUP, then press the right arrow to select SETUP.

4 Press the OK button to display the Mode setting screen.

5 Press the top/bottom arrows on the Jog dial to select .

6 Press the right arrow on the Jog dial, then press the top/bottom arrows to select HIGH, LOW or OFF.

7 Press the left arrow on the Jog dial to confirm the setting.

8 Press the OK button to save the setting. Press again to cancel the Menu.

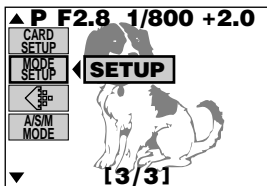

(Still picture record menu)

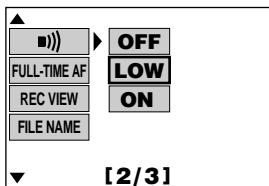

Note:

- The setting will remain until it is readjusted.

FULL-TIME AF

Full-time AF keeps the image on the LCD monitor in focus at all times without having to press the Shutter release button.

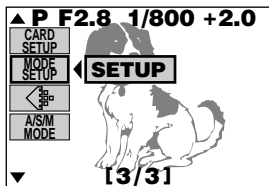
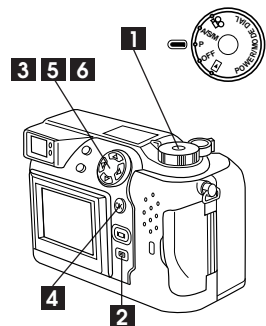

(Still picture record menu)

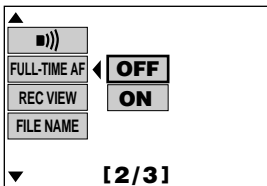

1 Set the Mode dial to P or A/S/M.

2 Press the Menu button to display the Menu.

3 Press the top/bottom arrows on the Jog dial to select MODE SETUP, then press the right arrow to select SETUP.

4 Press the OK button to display the MODE SETUP screen.

5 Press the top/bottom arrows on the Jog dial to select FULL-TIME AF.

6 Press the right arrow on the Jog dial, then press the top/bottom arrows to select ON or OFF.

- ON: Always maintains focus automatically.

- OFF: Turns off Full-time AF. The camera won't focus until you press the Shutter release button halfway.

FULL-TIME AF (Cont.)

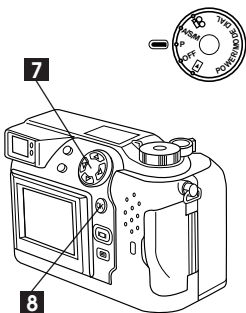

7 Press the left arrow on the Jog dial to confirm the setting.

8 Press the OK button to save the setting. Press again to cancel the Menu.

Note:

- Using Full-time AF will drain the battery more quickly.
- Full-time AF is not available when the LCD monitor is turned off.
- The setting will remain until it is readjusted.

REC VIEW

Rec view lets you select whether to display the image after recording. Rec check lets you check the image and decide whether or not to save it.

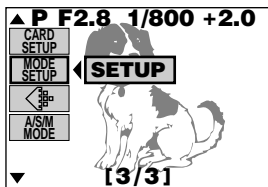
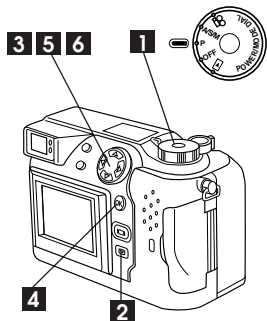

(Still picture record menu)

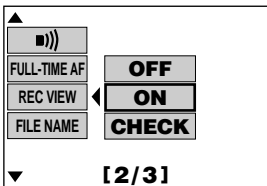

1 Set the Mode dial to P, A/S/M or .

2 Press the Menu button to display the Menu.

3 Press the top/bottom arrows on the Jog dial to select MODE SETUP, then press the right arrow to select SETUP.

4 Press the OK button to display the Mode setting screen.

5 Press the top/bottom arrows on the Jog dial to select REC VIEW.

6 Press the right arrow on the Jog dial, then press the top/bottom arrows to select ON, OFF or CHECK.

- When OFF is selected, the image will not be displayed on the LCD monitor after it is recorded.

- When ON is selected, the image will be displayed on the LCD monitor after it is recorded.

- When CHECK is selected, the image will be displayed after it is taken and a confirmation screen will be displayed to allow you to keep or discard it.

REC VIEW (Cont.)

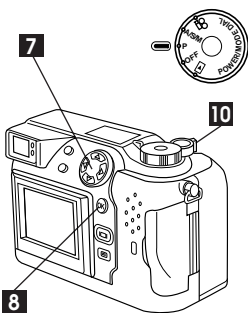

7 Press the left arrow on the Jog dial to confirm the setting.

8 Press the OK button to save the setting. Press again to cancel the Menu.

9 When CHECK is selected, the Save confirmation screen will appear.

- After recording a movie, it will be played back on the Save confirmation screen.
- If two or more images are in memory, you can use the Jog dial to select which one to view. You can also use the Zoom lever to enlarge images or display an index of images.

◁ : Displays the image in the previous frame.

▷ : Displays the image in the next frame.

△ : Displays the first frame.

▽ : Displays the last frame.

- If Bracketing was used to take a picture, the darkest frame will be displayed first. Press the left arrow on the Jog dial to display the next brightest image.
- CHECK is not available in the TIFF mode.

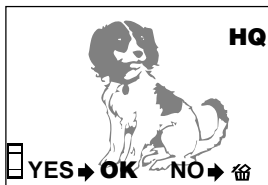

Confirmation screen (still image recording mode)





Confirmation screen (movie recording mode)

10 Turn the Zoom lever toward T to enlarge an image and toward W to view an index of images.

- The index will look different if Bracketing was used to take a picture. (p. 204)

REC VIEW (Cont.)

Note:

- After recording a movie or taking a picture with Bracketing, you must choose whether to save or discard it before you can record another image.
- Do not set CHECK in the TIFF mode. If you set it, the recording mode will be changed to the HIGH (high quality) mode which has the same number of pixels as it.
- You can record images while the Save confirmation screen is displayed. Press the Shutter release button halfway to change to the recording mode. The recording view with focus lock will appear on the LCD monitor. If no action is performed, the screen will automatically change back to the Save confirmation screen in 5 seconds.
- If there are some images whose CHECK setting is not completed, it is not possible to change or select the following menu settings when you record again with the Mode dial set to P or A/S/M. DRIVE, , , CARD SETUP and MODE SETUP.
- You can set the Mode dial to P or A/S/M while the Save confirmation screen is displayed. If you set the Mode dial to , all the images in memory will be stored automatically in the card.
- Never remove the card or batteries during CHECK. You will lose all of the data in the memory.
- You cannot display the Menu screen at the same time as the Save confirmation screen.
- The setting will remain until it is readjusted.

If Bracketing was used to take a picture, the index will appear as shown below.



Image shot with Bracketing

If the memory only contains an image shot with Bracketing, all of its frames will appear in the index.



Image shot with normal images

To display an image shot with Bracketing, select the image and press the OK button.

Press the OK button to save the selected image. To discard the image, press the Erase button then perform step **14** on page 203. It will disappear from the screen.

Save or delete all images in memory.

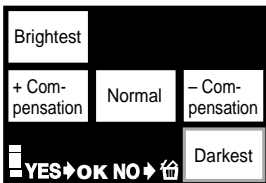

Image shot with Bracketing
(1 frame discarded)



Image shot with Bracketing
(5 frames)

Images shot with bracketing are displayed as shown on the left.



Note:

- If Bracketing was used to take a picture, you must choose whether to save or discard it before you can record another image.
- Also refer to Note on page 203.

FILE NUMBER

You can select the file numbering system for images transferred to a personal computer. Files can be numbered from 0001 to 9999 and folders can be numbered from 100 to 999.

ABOUT THE FILE NO. AND FOLDER NO.

The file number and folder number used for each image are expressed as shown.

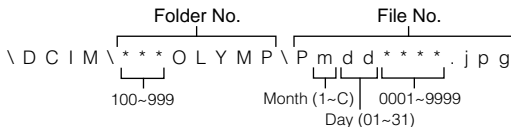

*Month: Jan. ~ Sep. = 1-9, Oct. = A, Nov. = B, Dec. = C

THE FILE NO. AND FOLDER NO. IN EACH MODE

• RESET

When RESET is selected, the file number and folder number will be reset every time a card is inserted in the camera.

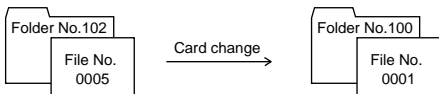

• AUTO

When AUTO is selected, the same folder number and a continuing number from the last file number of the last card will be used, so that the same file number will not be used for pictures taken together and saved in multiple cards.

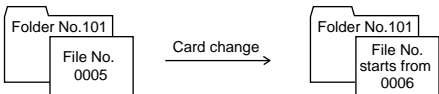

FILE NUMBER (Cont.)

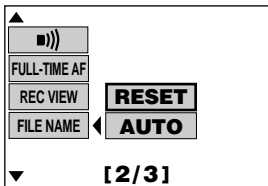
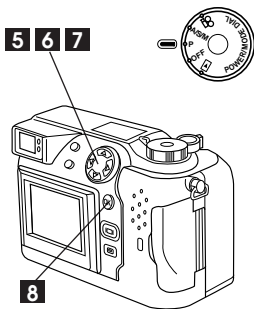

5 Press the top/bottom arrows on the Jog dial to select FILE NAME.

6 Press the right arrow on the Jog dial, then press the top/bottom arrows to select RESET or AUTO.

- If you select RESET, the folder and file numbers will be reset each time a new card is inserted. If you select AUTO, the folder number used by the last card will be kept, and the file number will continue from the last one in the previous card. File names will therefore not be repeated, even if you record several pictures in different cards at one time.

7 Press the left arrow on the Jog dial to confirm the setting.

8 Press the OK button to save the setting. Press again to cancel the Menu.

Note:

- When a card with a file number larger than the last file number is used, the file numbers will continue from the larger number.
- When the maximum file number (9999) is reached, the number of storable pictures becomes 0 even if the card is not full yet, and no more pictures can be taken.
- The setting will remain until it is readjusted.

LCD BRIGHTNESS

You can adjust the brightness of the LCD monitor.

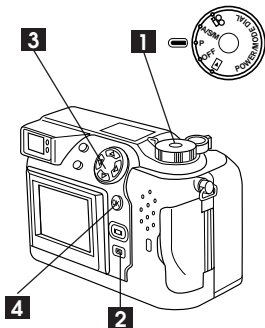

.....

1 Set the Mode dial to P, A/S/M, or .

2 Press the Menu button to display the Menu.

3 Press the top/bottom arrows on the Jog dial to select MODE SETUP, then press the right arrow to select SETUP.

4 Press the OK button to display the Mode setting screen.

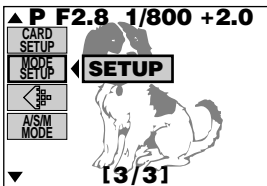

(Still picture record menu)

LCD BRIGHTNESS (Cont.)

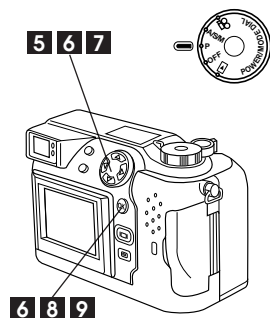

- 5** Press the top/bottom arrows on the Jog dial to select .

- 6** Press the right arrow on the Jog dial to select SETUP, then press the OK button.

-  -|.....+ appears on the LCD monitor.

- 7** Press the right/left arrows on the Jog dial to select the brightness.

- 8** Press the OK button to confirm the setting.

- 9** Press the OK button to save the setting. Press again to cancel the Menu.

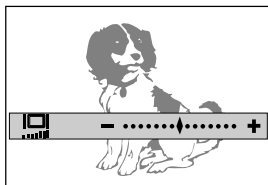
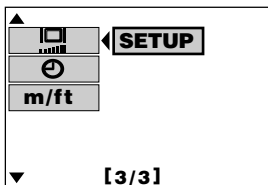

Note:

- The setting will remain until it is readjusted.

METERS/FEET SELECTION

You can select meters or feet to be used by the Manual focus setting screen. (In the Macro mode, the unit will shift between centimeters and inches.)

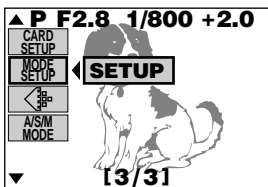
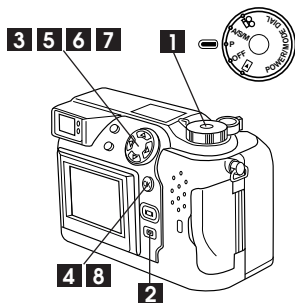

(Still picture record menu)

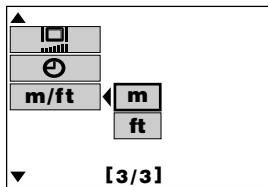

.....

1 Set the Mode dial to P, A/S/M or .

2 Press the Menu button to display the Menu.

3 Press the top/bottom arrows on the Jog dial to select MODE SETUP, then press the right arrow to select SETUP.

4 Press the OK button to display the Mode setting screen.

5 Press the top/bottom arrows on the Jog dial to select m/ft.

6 Press the right arrow on the Jog dial, then press the top/bottom arrows to select m (meters) or ft (feet).

7 Press the left arrow on the Jog dial to confirm the setting.

8 Press the OK button to save the setting. Press again to cancel the Menu.

Note:

- The setting will remain until it is readjusted.

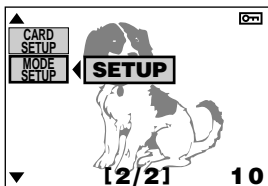
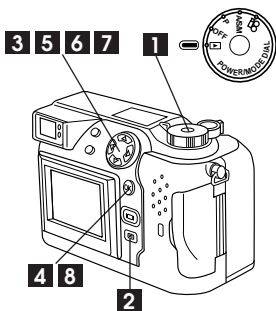

INDEX-DISPLAY ADJUSTMENT

You can select the number of frames shown in the Index-Display mode.

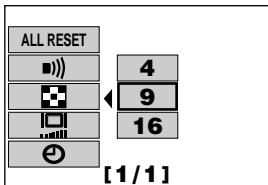

(Still picture display menu)



- 1 Set the Mode dial to .
- 2 Press the Menu button to display the Menu.
- 3 Press the top/bottom arrows on the Jog dial to select MODE SETUP, then press the right arrow to select SETUP.
- 4 Press the OK button to display the Mode setting screen.
- 5 Press the top/bottom arrows on the Jog dial to select .
- 6 Press the right arrow on the Jog dial, then press the top/bottom arrows to select the number.
- 7 Press the left arrow on the Jog dial to confirm the setting.
- 8 Press the OK button to save the setting. Press again to cancel the Menu.

Note:

- If no image is recorded in the card, the Menu screen will not be displayed when the Menu button is pressed.
- The setting will remain until it is readjusted.

CAMERA

7

MISCELLANEOUS

OLYMPUS DIGITAL CAMERA

QUESTIONS AND ANSWERS

Q

How long will the batteries last?

A

Battery life is affected by many variables such as the amount of LCD monitor use, the frequency of flash use, as well as by the kind of battery used and the environmental conditions under which the camera is used. Using the LCD monitor frequently will use up your batteries quickly. Keep the LCD monitor turned off to save power. Use of the optional AC adapter is recommended.

Q

How can I correct the clock in the camera that will be used to record the date on the image data?

A

Date adjustment is not made when the camera is shipped. You can adjust the date either from the camera or from the computer. (p. 28)

Q

How should I store the camera?

A

Cameras are susceptible to damage caused by dust, moisture, and salt. Wipe and dry the camera thoroughly before storing it. After using it at the beach, wipe it with a cloth that has been moistened with fresh water and then wrung out. Do not store in an area where mothballs are used. Unload the batteries if you do not plan to use the camera for a long period.

Q

Why do the subjects' eyes sometimes appear red in pictures?

A

This "red-eye phenomenon" occurs with all cameras when a flash is used. It is caused by light from the flash reflecting off the retina at the back of the eye. Red-eye varies depending on the individual and the shooting conditions such as ambient lighting. Use of the Red-Eye Reducing Pre-Flash mode significantly reduces this phenomenon.



Q

Can I use a filter, hood or conversion lens?

A

You cannot use a filter or a hood. A conversion lens adapter (optional) is required to attach a conversion lens to the camera.

Q

Can I use an extension flash?

A

Yes you can. You can use an extension flash with a grip (p. 84). For more information, please see our Internet home page (<http://www.olympus.com>).





TROUBLESHOOTING

OPERATING PROBLEMS

The camera does not work.

- ① The power is OFF.
→ Set the Mode dial to turn on the power. (P. 30)
- ② The batteries are loaded incorrectly.
→ Reload the batteries correctly. (P. 22)
- ③ The batteries are exhausted.
→ Replace the batteries with new ones. (P. 22)
- ④ The batteries are temporarily unable to function.
→ Keep the batteries warm while using the camera.
- ⑤ Power has shut off to conserve battery consumption.
→ Operate the shutter button or the zoom lever.
- ⑥ It is connected to a personal computer.
→ The camera will not operate while it is connected to a personal computer.

No picture is taken when the Shutter release button is pressed.

- ① The flash has not finished charging or the previous picture is being written into the card.
→ Remove your finger from the Shutter release button and wait until the Green lamp or the Orange lamp stops blinking. (P. 42/58)
- ② There is a problem with the card.
→ See the Error code chart. (P. 221)
- ③ The card is full.
→ Replace the card, delete unwanted pictures or transfer the data to a computer and delete all of the pictures. (P. 26/107/114/174 ~ 178)
- ④ The batteries ran out.
→ Replace the batteries with new ones. (P. 22)
- ⑤ The battery power is low.
→ Replace the batteries with new ones. (Do not open the Battery compartment cover when the Card access lamp is blinking.) (P. 22)
- ⑥ The buffer memory is full.
→ Wait until there is room in the buffer. (P. 45/123)
- ⑦ A write-protect adhesive seal is placed on the card or there is no card in the camera.
→ Insert a new card in the camera. (P. 26)
- ⑧ The Mode dial is set to .
→ Set the Mode dial to P, A/S/M or . (P. 31)

The flash does not fire.

- ① The flash mode was set to the Off mode.
 - Check the flash mode before shooting. (In the Sequence mode and the Panorama mode, the flash cannot be used.) (P. 58)
- ② The subject is lighted.
 - Set the flash to Fill-In mode. (P. 58/60)

The pictures already taken do not appear on the LCD monitor.

- ① The camera is in the Record Mode.
 - Set the Mode dial to . (P. 102/146)
- ② There is no picture in the card.
 - NO PICTURE appears on the LCD monitor. (P. 102)
- ③ There is a problem with the card.
 - See the Error code chart. (P. 221)
- ④ It is connected to a TV.
 - The LCD monitor is turned off while the camera is connected to a TV. (P. 118)

The LCD monitor is hard to read.

- ① The brightness may be incorrectly set.
 - Adjust the brightness. (P. 209)
- ② It is under sunlight.
 - Block the sunlight.
- ③ The LCD monitor is broken.
 - Have it repaired.

When the camera is connected to a computer, an error message appears while data is being transferred to the computer.

- ① The cable is not plugged in correctly.
 - Connect the cable correctly. (P. 176/177)
- ② The power is OFF.
 - Set the Mode dial . (P. 177)
- ③ The batteries are exhausted.
 - Replace the batteries with new ones (P. 22) or use the optional AC adapter (P. 24).
- ④ The serial port is not selected correctly.
 - Use the operating system software to make sure the serial port is selected correctly.
- ⑤ There is no available serial port.
 - Make one available by following the computer's instructions.

TROUBLESHOOTING (Cont.)

Image protect, Single-erase, All-frame erase or Card format cannot be performed.

- ① A write-protect adhesive seal is affixed to the card.
→ Use the card after peeling off the seal. Do not reuse the write protect seal. (P. 115)

PROBLEMS WITH IMAGES

The picture is out of focus

- ① The camera moved when the shutter button was pressed.
→ Hold the camera correctly, and press the shutter button. (P. 32/33)
- ② The viewfinder's autofocus mark was not positioned on the subject.
→ Position the autofocus frame on the subject, or use the focus lock. (P. 47/125)
- ③ The lens is dirty.
→ Clean the lens with a soft dry cloth.
- ④ The mode was not selected correctly.
→ Shoot with the Macro mode when the subject is within the range of 0.2 m ~ 0.8 m. For further distances, shoot with the Standard mode. (P. 50/63)
- ⑤ The Shutter release button was pressed while standing in front of the camera in the Selftimer mode.
→ Press the Shutter release button while looking into the viewfinder, not while standing in front of the camera. Or, use the remote control. (P. 70/132)
- ⑥ The Manual focus was used with the wrong focal range.
→ Use the right Manual focus for the distance. (P. 65/129)

The picture is too dark.

- ① The flash was blocked by a finger.
→ Hold the camera correctly, keeping your fingers away from the flash. (P. 32)
- ② The subject was out of the working range of the flash.
→ Shoot within the flash working range. Or, use an extension flash. (P. 58/86)
- ③ The flash mode was set to the Off mode.
→ Check the flash mode before shooting. (P. 58)

- ④ The subject was too small and was backlit.
→ Set the flash to Fill-In mode. (P. 58) Or, use the Spot metering mode. (P. 62)
- ⑤ The Sequence mode was used.
→ The shutter speed is high, so in dark conditions pictures will be darker than normal.

The picture is too bright.

- ① The flash mode was set to the Fill-in flash mode.
→ Select a flash mode other than the Fill-in flash mode. (P. 58)
- ② The subject was excessively illuminated.
→ Adjust the exposure compensation or change the camera position toward the subject. (P. 57/128)

The colors of pictures taken indoors look unnatural.

- ① The lighting fixture(s) affected the picture.
→ Set the flash mode to Fill-In. (P. 58)
- ② The subject is mostly dark.
→ Include white in the image or adjust the white balance. (P. 76/136)
- ③ The white balance setting is wrong.
→ Adjust the white balance. (P. 76/136)

The picture has obscured edge(s).

- ① The lens was partly blocked by a finger or the strap.
→ Hold the camera correctly, keeping your fingers and the strap away from the lens. (P. 32)
- ② The shooting distance was too close.
→ Use the LCD monitor. (P. 44/122)

SYSTEM CHART

A variety of capabilities are available when connected to optional equipment.

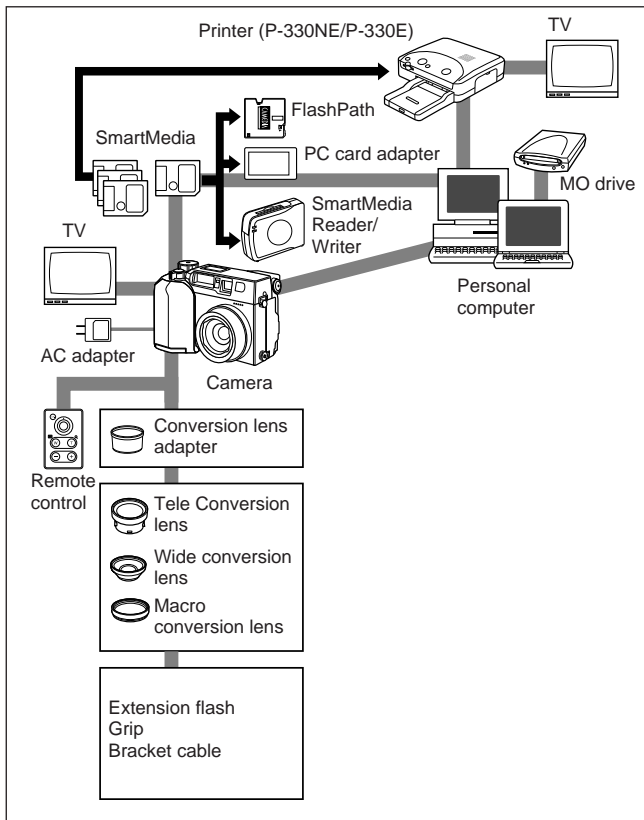







ERROR CODES

Error codes appear when there is a problem with the camera.
Error codes displayed on the control panel will flash.

Control panel	LCD monitor	Error content	Remedy
-0-	CARD COVER OPEN	The card cover is open.	Insert a card and close the cover.
Ⓜ - - -	NO CARD	The card is not inserted, or it cannot be recognized.	Insert a card. Or insert the card again.
Ⓜ 0	CARD FULL	No more pictures can be taken.	Replace the card or erase unneeded pictures.
Ⓜ -P-	WRITE PROTECT	Writing to the card is prohibited.	If you are taking pictures, remove the write-protect adhesive seal.
Ⓜ -E-	CARD ERROR	Cannot record, play back or erase pictures in this card.	If the card is dirty, wipe it with a clean tissue and insert it again. Or, format the card. If the problem is still not corrected, this card cannot be used.
(No display)	PICTURE ERROR	The recorded image cannot be played back with this camera.	Load the image using personal computer image processing software. If that cannot be done, the image file is partially damaged.

ERROR CODES (Cont.)

Control panel	LCD monitor	Error content	Remedy
 	(Format confirmation screen)	The card is not formatted.	Format the card.
 	NO PICTURE	There are no pictures in the card, so there is nothing to play back.	Insert a card which contains images.
 	CARD FULL	There is no empty space in the card, so print data or sound cannot be recorded.	Replace the card or erase unneeded pictures.

OPTIONAL ITEMS

- Photo Printers For Olympus Digital Cameras
- AC Adapter
- Camera Case
- Standard SmartMedia Card (8/16/32/64MB)
- Leather SmartMedia Case
- FL-40 extension flash
- Exclusive Grip
- Bracket cable
- FlashPath Floppy Disk Adapter
- PC Card Adapter
- NiMH Batteries
- NiMH Battery Charger
- USB SmartMedia Reader/Writer

NOTES ON DISPLAY AND BACKLIGHT

- The Control panel and the fluorescent lamps used in the LCD monitor have a limited service life. If they begin to darken or flicker, contact your nearest service center.
- In cold conditions, the display backlight may be slow to come on or may change color suddenly. To avoid this, keep the camera warm when using in cold temperatures. Backlight performance will return to normal under normal temperature conditions.
- When the color LCD monitor shows different pictures, some pixels may not change color and remain on or off. This phenomenon may be due to a lag in some circuits, but is considered to be within the normal operating tolerances of the LCD monitor. In addition, the brightness of the color LCD monitor may vary between pictures.

COMPATIBILITY OF PICTURE DATA

- Images taken by this camera may not be properly displayed or printed with other Olympus digital cameras.
- Images taken by other Olympus digital cameras may not be properly displayed with this camera.

When taken with this camera and displayed/printed with other models

Models	Display	Direct print
C-960ZOOM	○ *1	×
C-860L	○ *1 *2	×
C-2020ZOOM	○ *1	○
C-21	○ *1	○
C-2500L	○ *1	×
C-920ZOOM	○	○
C-2000ZOOM	○	○
C-900ZOOM	×	×
C-830L	×	×
C-840L	×	×
C-820L	×	×
C-420L	×	×
C-1400XL	×	×
C-1400L	×	×
C-1000L	×	×

*1: Large image files may be displayed as an index.

*2: Images taken in the TIFF recording mode cannot be displayed.

When taken with other models and displayed with this camera

Models	Display
C-960ZOOM	○
C-860L	○
C-2020ZOOM	○
C-21	○
C-2500L	○*1
C-920ZOOM	○
C-2000ZOOM	○
C-900ZOOM	○
C-830L	○
C-840L	○
C-820L	○
C-420L	○
C-1400XL	○
C-1400L	○
C-1000L	○

- *1: • Only images taken in the SQ recording mode can be displayed.
• Close-up display mode is not available.

SPECIFICATIONS

Product type	: Digital camera (for shooting and displaying)
Recording System	
Still	: Digital recording, JPEG (in accordance with Design rule for Camera File system (DCF)), TIFF (non-compression), Digital Print Order Format (DPOF)
Sound with still images	: Wave format
Movie	: QuickTime Motion JPEG support
Memory	: 3V (3.3V) SmartMedia 2MB, 4MB, 8MB, 16MB, 32MB, 64MB
No. of storable pictures (When a 16 MB card is used)	: Approx. 1 frame (TIFF/2048 x 1536) : Approx. 6 frames (SHQ) : Approx. 20 frames (HQ) : Approx. 49 frames (SQ1/1280 x 960 NORMAL) : Approx. 165 frames (SQ2/640 x 480 NORMAL)
Erase	: One-Frame erase / All-Frames erase
Image pickup element	: 1/1.8 inch CCD solid-state image pickup : 3,340,000 pixels (gross)
Recording image	: 2048 x 1536 pixels (TIFF/SHQ/HQ) : 1600 x 1200 pixels (TIFF/SQ1) : 1280 x 960 pixels (TIFF/SQ1) : 1024 x 768 pixels (TIFF/SQ2) : 640 x 480 pixels (TIFF/SQ2)
White balance	: Full Auto TTL (iESP auto), Preset (Daylight, Overcast, Tungsten light, Fluorescent)
Lens	: Olympus lens 6.5 ~ 19.5 mm, F2.8, 6 elements in 8 groups (equivalent to 32 ~ 96 mm lens on 35 mm camera), aspherical glass
Photometric system	: Digital ESP metering system, Spot metering system
Exposure control	: Program auto, Aperture priority, Shutter priority, Manual
Aperture	: W : F2.8 ~ 11.0 : T : F2.8 ~ 11.0

Shutter speed	: Used with mechanical shutter
Still	: 1 ~ 1/800 sec. (16 ~ 1/800 sec. with manual setting)
Movie	: 1/30 ~ 1/10000 sec.
Working range	: 0.8 m ~ ∞ (Standard mode) 0.2 m ~ 0.8 m (Macro mode)
Viewfinder	: Optical real image viewfinder (Autofocus mark/Backlighting correction mark), LCD monitor
LCD monitor	: 1.8" TFT color LCD display
No. of pixels	: Approx. 114,000 pixels
On-screen display	: Date/Time, Frame number, Protect, Recording mode, Battery check, Picture information, Print-reserve, Menu, etc.
Battery charging time for flash	: Approx. 6 sec. (at normal temperature with new batteries)
Flash working range	: W : Approx. 0.8 m ~ 3.8 m T : Approx. 0.2 m ~ 3.8 m
Flash modes	: Auto-Flash (automatic flash activation in low light and backlight), Red-Eye Reducing Flash, Fill-In Flash (forced activation), Off (no flash)
Autofocus	: TTL system iESP autofocus, Contrast detection system
Focusing range	: 0.2 m ~ ∞
Selftimer	: Electronic Selftimer with 12-sec. delay
Outer connectors	: AC adapter connector, Computer connector (RS-232C), A/V output connector, USB terminal (USB 1.0 compatible), Extension flash connector
Date and time	: Recorded with picture data simultaneously
Automatic calendar system	: Up to 2030
Operating environment	
Temperature	: 0 ~40°C (operation) - 20 ~ 60°C (storage)
Humidity	: 30 ~ 90% (operation) 10 ~ 90% (storage)

SPECIFICATIONS (Cont.)

Power supply	: For batteries, use 2 CR-V3 lithium battery packs, or 4 AA (R6) NiMH batteries, NiCd batteries, alkaline batteries or lithium batteries. AC adapter (optional)
Dimensions	: 109.5 (W) x 76.4 (H) x 66.4 (D) mm
Weight	: 300g (without batteries/card)

SPECIFICATIONS ARE SUBJECT TO CHANGE WITHOUT ANY NOTICE OR OBLIGATION ON THE PART OF THE MANUFACTURER.

OLYMPUS®

OLYMPUS OPTICAL CO., LTD.

San-Ei Building, 22-2, Nishi Shinjuku 1-chome, Shinjuku-ku, Tokyo, Japan. Tel. 03-3340-2026

OLYMPUS AMERICA INC.

Two Corporate Center Drive, Melville, NY 11747-3157, U.S.A. Tel. 516-844-5000

(Customer support) Tel. 1-888-553-4448

www.olympusamerica.com

distec@olympus.com

OLYMPUS OPTICAL CO. (EUROPA) GMBH.

(Premises/Goods delivery) Wendenstraße 14-16, 20097 Hamburg, Germany. Tel. 040-237730

(Letters) Postfach 10 49 08, 20034 Hamburg, Germany.

www.olympus-europa.com

OLYMPUS OPTICAL CO. (U.K.) LTD.

2-8 Honduras Street, London EC1Y 0TX, United Kingdom. Tel. 0171-253-2772



- "CE" mark indicates that this product complies with the European requirements for safety, health, environment and customer protection.
 - La marque "CE" indique que ce produit est conforme avec les exigences européennes en matière de sécurité, santé, environnement et protection du consommateur.
 - Das CE-Zeichen bestätigt, daß dieses Produkt mit den europäischen Bestimmungen für Sicherheit, Gesundheit, Umweltschutz und Personenschutz übereinstimmt.
-